

INSTALLATION INSTRUCTIONS



Air Conditioner

This air conditioner uses the refrigerant R410A.

Model No.

Outdoor Units		Rated Capacity						
Type	Outdoor Unit Type	8 HP ¹	10 HP ¹	12 HP ¹	14 HP ¹	16 HP ¹	18 HP	20 HP
ME2	2WAY System	U-8ME2R8	U-10ME2R8	U-12ME2R8	U-14ME2R8	U-16ME2R8	U-18ME2R8	U-20ME2R8
		U-8ME2R8E ²	U-10ME2R8E ²	U-12ME2R8E ²	U-14ME2R8E ²	U-16ME2R8E ²	U-18ME2R8E ²	U-20ME2R8E ²

¹ Should you wish to use as space saving combination, read this Installation Instructions.

² Salt-air damage resistant

- To be connecting Indoor Unit

Indoor Units		Rated Capacity					
Type	Indoor Unit Type	22	28	36	45	56	60
D1	1-Way Cassette		S-28MD1E5	S-36MD1E5	S-45MD1E5	S-56MD1E5	
L1	2-Way Cassette	S-22ML1E5	S-28ML1E5	S-36ML1E5	S-45ML1E5	S-56ML1E5	
U1	4-Way Cassette	S-22MU1E5A	S-28MU1E5A	S-36MU1E5A	S-45MU1E5A	S-56MU1E5A	S-60MU1E5A
Y2	4-Way Cassette 60 × 60	S-22MY2E5A	S-28MY2E5A	S-36MY2E5A	S-45MY2E5A	S-56MY2E5A	
K1	Wall-Mounted				S-45MK1E5A	S-56MK1E5A	
K2	Wall-Mounted	S-22MK2E5A	S-28MK2E5A	S-36MK2E5A			
T2	Ceiling			S-36MT2E5A	S-45MT2E5A	S-56MT2E5A	
F2	Low Silhouette Ducted	S-22MF2E5A	S-28MF2E5A	S-36MF2E5A	S-45MF2E5A	S-56MF2E5A	S-60MF2E5A
M1	Slim Low Static Ducted	S-22MM1E5A	S-28MM1E5A	S-36MM1E5A	S-45MM1E5A	S-56MM1E5A	
P1	Floor Standing	S-22MP1E5	S-28MP1E5	S-36MP1E5	S-45MP1E5	S-56MP1E5	
R1	Concealed Floor Standing	S-22MR1E5	S-28MR1E5	S-36MR1E5	S-45MR1E5	S-56MR1E5	
Z1	Slim Type Ducted	S-22MZ1H4A	S-28MZ1H4A	S-36MZ1H4A	S-45MZ1H4A	S-56MZ1H4A	S-60MZ1H4A

Type	Indoor Unit Type	Rated Capacity				
		73	90	106	140	160
D1	1-Way Cassette	S-73MD1E5				
L1	2-Way Cassette	S-73ML1E5				
U1	4-Way Cassette	S-73MU1E5A	S-90MU1E5A	S-106MU1E5A	S-140MU1E5A	S-160MU1E5A
K1	Wall-Mounted	S-73MK1E5A		S-106MK1E5A		
T2	Ceiling	S-73MT2E5A		S-106MT2E5A	S-140MT2E5A	
F2	Low Silhouette Ducted	S-73MF2E5A	S-90MF2E5A	S-106MF2E5A	S-140MF2E5A	S-160MF2E5A
E1	High Static Pressure Ducted	S-73ME1E5		S-106ME1E5	S-140ME1E5	
P1	Floor Standing	S-71MP1E5				
R1	Concealed Floor Standing	S-71MR1E5				
Z1	Slim Type Ducted	S-73MZ1H4A				

Type	Indoor Unit Type	Rated Capacity		
		180	224	280
E1	High Static Pressure Ducted		S-224ME1E5	S-280ME1E5
E2	High Static Pressure Ducted	S-180ME2E5	S-224ME2E5	S-280ME2E5



Read through the Installation Instructions before you proceed with the installation. In particular, you will need to read under the "IMPORTANT!" section at the top of the page.

IMPORTANT!

Please Read Before Starting

This air conditioner must be installed by the sales dealer or installer.

This information is provided for use only by authorized persons.

For safe installation and trouble-free operation, you must:

- Carefully read this instruction booklet before beginning.
- Follow each installation or repair step exactly as shown.
- This air conditioner shall be installed in accordance with National Wiring Regulations.
- This product is intended for professional use. Permission from the power supplier is required when installing the U-8ME2R8(E) and U-10ME2R8(E) outdoor units that are connected to a 16 A distribution network.
- This equipment complies with EN/IEC 61000-3-12 provided that the short-circuit power S_{sc} is greater than or equals to the values corresponding to each model as shown in the table below at the interface point between the user's supply and the public system. It is the responsibility of the installer or user of the equipment to ensure; by consultation with the distribution network operator if necessary that the equipment is connected only to supply with a short-circuit power S_{sc} greater than or equals to the values corresponding to each model as shown in the table below.

	U-12ME2R8(E)	U-14ME2R8(E)	U-16ME2R8(E)
Ssc	1,550 kVA	1,550 kVA	1,550 kVA

	U-18ME2R8(E)	U-20ME2R8(E)
Ssc	1,550 kVA	1,550 kVA

- The product meets the technical requirements of EN/IEC 61000-3-3.
- Pay close attention to all warning and caution notices given in this manual.

 **WARNING** This symbol refers to a hazard or unsafe practice which can result in severe personal injury or death.

 **CAUTION** This symbol refers to a hazard or unsafe practice which can result in personal injury or product or property damage.

If Necessary, Get Help

These instructions are all you need for most installation sites and maintenance conditions. If you require help for a special problem, contact our sales/service outlet or your certified dealer for additional instructions.

In Case of Improper Installation

The manufacturer shall in no way be responsible for improper installation or maintenance service, including failure to follow the instructions in this document.

SPECIAL PRECAUTIONS

WARNING When Wiring



ELECTRICAL SHOCK CAN CAUSE SEVERE PERSONAL INJURY OR DEATH. ONLY A QUALIFIED, EXPERIENCED ELECTRICIAN SHOULD ATTEMPT TO WIRE THIS SYSTEM.

- Do not supply power to the unit until all wiring and tubing are completed or reconnected and checked.
- Highly dangerous electrical voltages are used in this system. Carefully refer to the wiring diagram and these instructions when wiring. Improper connections and inadequate grounding can cause **accidental injury or death**.
- Connect all wiring tightly. Loose wiring may cause overheating at connection points and a possible fire hazard.
- Provide a power outlet to be used exclusively for each unit.
- ELCB must be incorporated in the fixed wiring. Circuit breaker must be incorporated in the fixed wiring in accordance with the wiring regulations.

	Circuit breaker		Circuit breaker
U-8ME2R8(E)	20 A	U-16ME2R8(E)	40 A
U-10ME2R8(E)	25 A	U-18ME2R8(E)	50 A
U-12ME2R8(E)	30 A	U-20ME2R8(E)	60 A
U-14ME2R8(E)	35 A		

- Provide a power outlet exclusively for each unit, and full disconnection means having a contact separation in all poles must be incorporated in the fixed wiring in accordance with the wiring rules.
- To prevent possible hazards from insulation failure, the unit must be grounded. 
- This equipment is strongly recommended to be installed with Earth Leakage Circuit Breaker (ELCB) or Residual Current Device (RCD). Otherwise, it may cause electrical shock and fire in case of equipment breakdown or insulation breakdown.

When Transporting

Be careful when picking up and moving the indoor and outdoor units. Get a partner to help, and bend your knees when lifting to reduce strain on your back. Sharp edges or thin aluminum fins on the air conditioner can cut your fingers.

When Installing...

Select an installation location which is rigid and strong enough to support or hold the unit, and select a location for easy maintenance.

...In a Room

Properly insulate any tubing run inside a room to prevent “sweating” that can cause dripping and water damage to walls and floors.



CAUTION

Keep the fire alarm and the air outlet at least 1.5 m away from the unit.

...In Moist or Uneven Locations

Use a raised concrete pad or concrete blocks to provide a solid, level foundation for the outdoor unit. This prevents water damage and abnormal vibration.

...In an Area with High Winds

Securely anchor the outdoor unit down with bolts and a metal frame. Provide a suitable air baffle.

...In a Snowy Area (for Heat Pump-type Systems)

Install the outdoor unit on a raised platform that is higher than drifting snow. Provide snow vents.

When Connecting Refrigerant Tubing

Pay particular attention to refrigerant leakages.



WARNING

- When performing piping work, do not mix air except for specified refrigerant (R410A) in refrigeration cycle. It causes capacity down, and risk of explosion and injury due to high tension inside the refrigerant cycle.
- If the refrigerant comes in contact with a flame, it produces a toxic gas.
- Do not add or replace refrigerant other than specified type. It may cause product damage, burst and injury, etc.
- Ventilate the room immediately, in the event that is refrigerant gas leaks during the installation. Be careful not to allow contact of the refrigerant gas with a flame as this will cause the generation of toxic gas.
- Keep all tubing runs as short as possible.
- Apply refrigerant lubricant to the matching surfaces of the flare and union tubes before connecting them, then tighten the nut with a torque wrench for a leak-free connection.
- Check carefully for leaks before starting the test run.
- Do not leak refrigerant while piping work for an installation or re-installation, and while repairing refrigeration parts. Handle liquid refrigerant carefully as it may cause frostbite.

When Servicing

- Turn the power OFF at the main power box (mains), wait at least 5 minutes until it is discharged, then open the unit to check or repair electrical parts and wiring. 
- Keep your fingers and clothing away from any moving parts.
- Clean up the site after you finish, remembering to check that no metal scraps or bits of wiring have been left inside the unit.



WARNING

- This product must not be modified or disassembled under any circumstances. Modified or disassembled unit may cause fire, electric shock or injury.
- Do not clean inside the indoor and outdoor units by users. Engage authorized dealer or specialist for cleaning.
- In case of malfunction of this appliance, do not repair by yourself. Contact the sales dealer or service dealer for a repair and disposal.







CAUTION

- Do not touch the air inlet or the sharp aluminum fins of the outdoor unit. You may get injured. 
- Ventilate any enclosed areas when installing or testing the refrigeration system. Leaked refrigerant gas, on contact with fire or heat, can produce dangerously toxic gas.
- Confirm after installation that no refrigerant gas is leaking. If the gas comes in contact with a burning stove, gas water heater, electric room heater or other heat source, it can cause the generation of toxic gas.

Others



CAUTION

- Do not touch the air inlet or the sharp aluminum fins of the outdoor unit. You may get injured. 
- Do not sit or step on the unit. You may fall down accidentally. 
- Do not stick any object into the FAN CASE. You may be injured and the unit may be damaged.  

Check of Density Limit

Check the amount of refrigerant in the system and floor space of the room according to the legislation on refrigerant drainage. If there is no applicable legislation, follow the standards described below.

The room in which the air conditioner is to be installed requires a design that in the event of refrigerant gas leaking out, its density will not exceed a set limit.

The refrigerant (R410A), which is used in the air conditioner, is safe, without the toxicity or combustibility of ammonia, and is not restricted by laws imposed to protect the ozone layer. However, since it contains more than air, it poses the risk of suffocation if its density should rise excessively. Suffocation from leakage of refrigerant is almost non-existent. With the recent increase in the number of high density buildings, however, the installation of multi air conditioner systems is on the increase because of the need for effective use of floor space, individual control, energy conservation by curtailing heat and carrying power, etc.

Most importantly, the multi air conditioner system is able to replenish a large amount of refrigerant compared to conventional individual air conditioners. If a single unit of the multi air conditioner system is to be installed in a small room, select a suitable model and installation procedure so that if the refrigerant accidentally leaks out, its density does not reach the limit (and in the event of an emergency, measures can be made before injury can occur).

In a room where the density may exceed the limit, create an opening with adjacent rooms, or install mechanical ventilation combined with a gas leak detection device. The density is as given below.

Total amount of refrigerant (kg)

$$\frac{\text{Min. volume of the indoor unit installed room (m}^3\text{)}}{\leq \text{Density limit (kg/m}^3\text{)}}$$

The density limit of refrigerant which is used in multi air conditioners is 0.44 kg/m³ (ISO 5149).

NOTE

- If there are 2 or more refrigerating systems in a single refrigerating device, the amount of refrigerant should be as charged in each independent device.

For the amount of charge in this example:

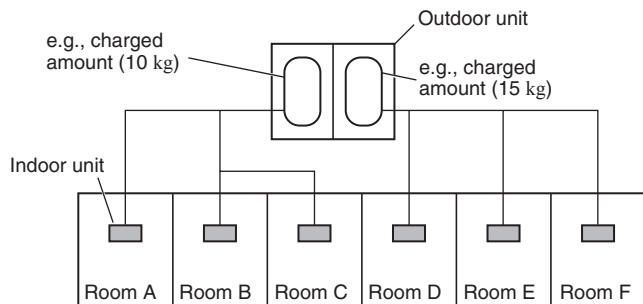

The possible amount of leaked refrigerant gas in rooms A, B and C is 10 kg.

The possible amount of leaked refrigerant gas in rooms D, E and F is 15 kg.

- The standards for minimum room volume are as follows.
 - No partition (shaded portion)

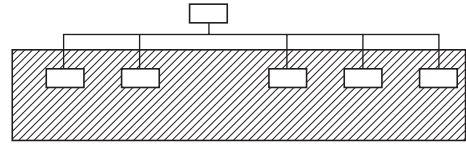

- When there is an effective opening with the adjacent room for ventilation of leaking refrigerant gas (opening without a door, or an opening 0.15% or larger than the respective floor spaces at the top or bottom of the door).

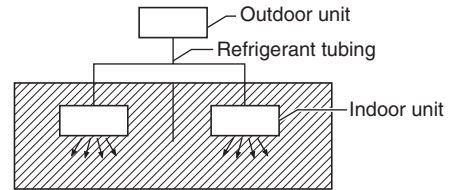

- If an indoor unit is installed in each partitioned room and the refrigerant tubing is interconnected, the smallest room of course becomes the object. But when mechanical ventilation is installed interlocked with a gas leakage detector in the smallest room where the density limit is exceeded, the volume of the next smallest room becomes the object.

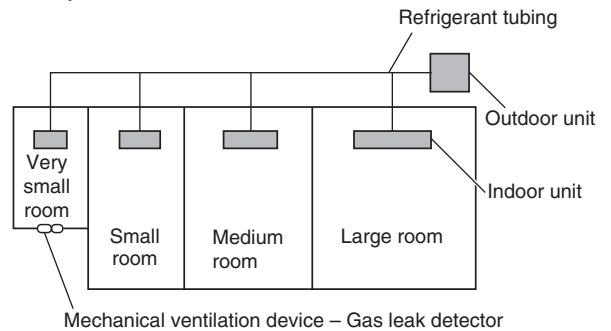

- The minimum indoor floor space compared with the amount of refrigerant is roughly as follows: (When the ceiling is 2.7 m high)

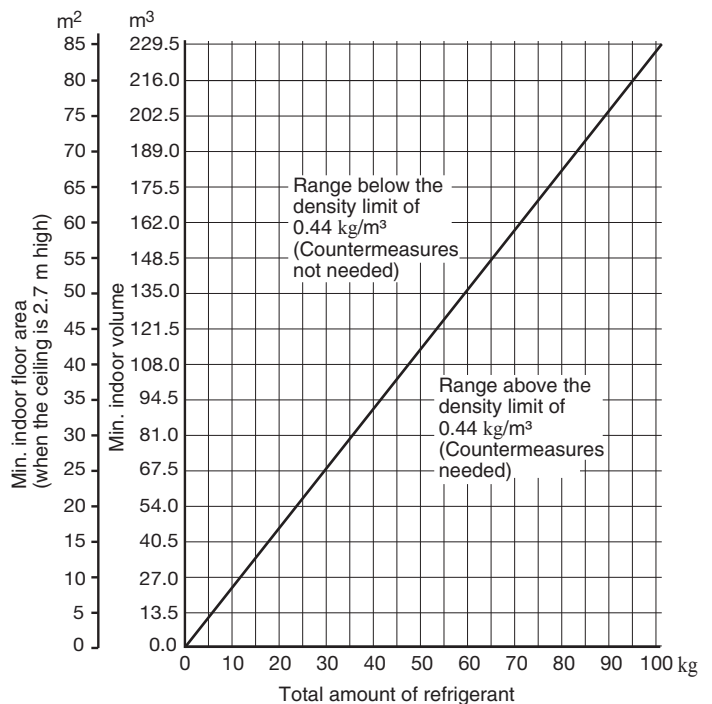

Precautions for Installation Using New Refrigerant

1. Care regarding tubing

1-1. Process tubing

- **Material:** Use seamless phosphorous deoxidized copper tube for refrigeration. Wall thickness shall comply with the applicable legislation. The minimal wall thickness must be in accordance with the table below. For tubes of $\phi 22.22$ or larger, use the material of temper 1/2H or H (Hard copper tube). Do not bend the hard copper tube.
- **Tubing size:** Be sure to use the sizes indicated in the table below.
- Use a tube cutter when cutting the tubing, and be sure to remove any flash. This also applies to distribution joints (optional).
- When bending tubing, use a bending radius that is 4 times the outer diameter of the tubing or larger.



CAUTION Use sufficient care in handling the tubing. Seal the tubing ends with caps or tape to prevent dirt, moisture, or other foreign substances from entering. These substances can result in system malfunction.

Unit: mm

Material		Temper - O (Soft copper tube)				
Copper tube	Outer diameter	6.35	9.52	12.7	15.88	19.05
	Wall thickness	0.8	0.8	0.8	1.0	1.2

Unit: mm

Material		Temper - 1/2 H, H (Hard copper tube)							
Copper tube	Outer diameter	22.22	25.4	28.58	31.75	38.1	41.28	44.45	50.8
	Wall thickness	1.0	1.0	1.0	1.1	over 1.35	over 1.45	over 1.55	over 1.8

1-2. Prevent impurities including water, dust and oxide from entering the tubing. Impurities can cause R410A refrigerant deterioration and compressor defects. Due to the features of the refrigerant and refrigerating machine oil, the prevention of water and other impurities becomes more important than ever.

2. Be sure to recharge the refrigerant only in liquid form.

- 2-1. Since R410A is a non-azeotrope, recharging the refrigerant in gas form can lower performance and cause defects in the unit.
- 2-2. Since refrigerant composition changes and performance decreases when gas leaks, collect the remaining refrigerant and recharge the required total amount of new refrigerant after fixing the leak.

3. Different tools required

- 3-1. Tool specifications have been changed due to the characteristics of R410A.
Some tools for R22- and R407C-type refrigerant systems cannot be used.

Item	New tool?	R407C tools compatible with R410A?	Remarks
Manifold gauge	Yes	No	Types of refrigerant, refrigerating machine oil, and pressure gauge are different.
Charge hose	Yes	No	To resist higher pressure, material must be changed.
Vacuum pump	Yes	Yes	Use a conventional vacuum pump if it is equipped with a check valve. If it has no check valve, purchase and attach a vacuum pump adapter.
Leak detector	Yes	No	Leak detectors for CFC and HCFC that react to chlorine do not function because R410A contains no chlorine. Leak detectors for HFC134a can be used for R410A.
Flaring oil	Yes	No	For systems that use R22, apply mineral oil (Suniso oil) to the flare nuts on the tubing to prevent refrigerant leakage. For machines that use R407C or R410A, apply synthetic oil (ether oil) to the flare nuts.

Manifold gauge

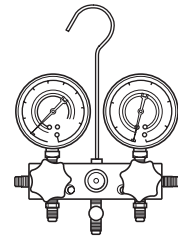

Vacuum pump

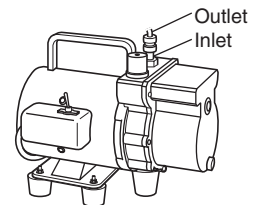

* Using tools for R22 and R407C and new tools for R410A together can cause defects.

3-2. Use R410A exclusive cylinder only.

Single-outlet valve (with siphon tube)

Liquid refrigerant should be recharged with the cylinder standing on end as shown.

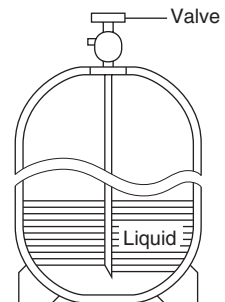

High-Durable Outdoor unit model

Outdoor unit model name ended with the letter "E" indicates salt-air damage resistant specifications.

Certain parts of this product are dual painted and reinforced for the use in harsh conditions, but it does not mean this product is free from rusting and corrosion.

Precaution on installation

Observe the following instructions for installation and maintenance of this unit.

- 1) Avoid installing the unit at a place where the unit is exposed to sea-spray as much as possible.
- 2) Give special consideration to the layout so the salt particles adhering to the outer panel can be washed away by the rain. (For example, avoid installing a shade over the unit.)
- 3) Because water retention in the bottom plate of the outdoor unit will significantly accelerate corrosion, pay attention to its slope and other installation conditions of the unit so the water can drain out easily.
- 4) When installing the unit in a coastal area, wash the unit with fresh water periodically to remove adhering salt build-up.
- 5) Repair any damage or scratch made during installation and maintenance.
- 6) Inspect the unit and other related devices periodically. (Perform rustproof treatment and the part replacement as necessary.)
- 7) Conduct water drainage measures on the unit installation base.

CONTENTS

	Page		Page
IMPORTANT!	2	6. AIR PURGING.	43
Please Read Before Starting			
Check of Density Limit		7. TEST RUN	45
Precautions for Installation Using New Refrigerant		7-1. Preparing for Test Run	
High-Durable Outdoor unit model		7-2. Test Run Procedure	
		7-3. Main Outdoor Unit PCB Setting	
1. GENERAL	9	7-4. Auto Address Setting	
1-1. Tools Required for Installation (not supplied)		7-5. Setting Test Run Remote Controller	
1-2. Accessories Supplied with Outdoor Unit		7-6. Caution for Pump Down	
1-3. Type of Copper Tube and Insulation Material		7-7. Self-Diagnosis Function Table and Contents of Alarm Display	
1-4. Additional Materials Required for Installation			
1-5. Tubing Length		SUPPLEMENT	64
1-6. Tubing Size			
1-7. Straight Equivalent Length of Joints			
1-8. Additional Refrigerant Charge			
1-9. System Limitations			
1-10. Check of Limit Density			
1-11. Installing Distribution Joint			
1-12. Optional Distribution Joint Kits			
1-13. Example of Tubing Size Selection and Refrigerant Charge Amount			
2. SELECTING THE INSTALLATION SITE	20		
2-1. Outdoor Unit			
2-2. Shield for Horizontal Exhaust Discharge			
2-3. Installing the Outdoor Unit in Heavy Snow Areas			
2-4. Precautions When Installing in Heavy Snow Areas			
2-5. Dimensions of Wind Ducting			
2-6. Dimensions of Snow Ducting			
3. HOW TO INSTALL THE OUTDOOR UNIT	22		
3-1. Transporting			
3-2. Installing the Outdoor Unit			
3-3. Routing the Tubing			
3-4. Prepare the Tubing			
3-5. Connect the Tubing			
4. ELECTRICAL WIRING	28		
4-1. General Precautions on Wiring			
4-2. Wire Length and Wire Diameter for Power Supply System			
4-3. Wiring System Diagram			
5. HOW TO PROCESS TUBING	38		
5-1. Connecting the Refrigerant Tubing			
5-2. Connecting Tubing Between Indoor and Outdoor Units			
5-3. Insulating the Refrigerant Tubing			
5-4. Taping the Tubes			
5-5. Finishing the Installation			

1. GENERAL

This booklet briefly outlines where and how to install the air conditioning system. Please read over the entire set of instructions for the outdoor unit and make sure all accessory parts listed are with the system before beginning.

1-1. Tools Required for Installation (not supplied)

1. Flathead screwdriver
2. Phillips head screwdriver
3. Knife or wire stripper
4. Tape measure
5. Carpenter's level
6. Sabre saw or keyhole saw
7. Hacksaw
8. Core bits
9. Hammer
10. Drill
11. Tube cutter
12. Tube flaring tool
13. Torque wrench
14. Adjustable wrench
15. Reamer (for deburring)
16. Hexagonal wrench (4 mm and 5 mm)
17. Pliers
18. Cutting pliers

1-2. Accessories Supplied with Outdoor Unit

See Table 1.

1-3. Type of Copper Tube and Insulation Material

If you wish to purchase these materials separately from a local source, you will need:

1. Deoxidized annealed copper tube for refrigerant tubing.
2. Foamed polyethylene insulation for copper tubes as required to precise length of tubing. See the section "5-3. Insulating the Refrigerant Tubing" for details.
3. Use insulated copper wire for field wiring. Wire size varies with the total length of wiring. See the section "4. ELECTRICAL WIRING" for details.





CAUTION

Check local electrical codes and regulations before obtaining wire. Also, check any specified instructions or limitations.

1-4. Additional Materials Required for Installation

1. Refrigeration (armored) tape
2. Insulated staples or clamps for connecting wire (See your local codes.)
3. Putty
4. Refrigeration tubing lubricant
5. Clamps or saddles to secure refrigerant tubing
6. Scale for weighing

Table 1 Outdoor Unit

Part Name	Figure	Q'ty						
		8 HP	10 HP	12 HP	14 HP	16 HP	18 HP	20 HP
Connection tubing (mm)	Outer diameter $\phi 28.58$  Inner diameter $\phi 25.4$	0	0	0	0	1	0	0
Operating Instructions		1	1	1	1	1	1	1
Installation Instructions		1	1	1	1	1	1	1

1-5. Tubing Length

Select the installation location so that the length and size of refrigerant tubing are within the allowable range shown in the figure below.

1. — Main tubing length (maximum tubing size of gas tube and liquid tube) $LM = LA + LB \dots$
2. — Main distribution tubes $LC - LH$ are selected according to the capacity after the distribution joint.
3. The outdoor connection main tubing (LO, LP portion) is determined by the total capacity of the outdoor units that are connected to the tube ends.
4. — Sizes of indoor unit connection tubing $\varnothing 1 - \varnothing 64$ are determined by the connection tubing sizes on the indoor units.

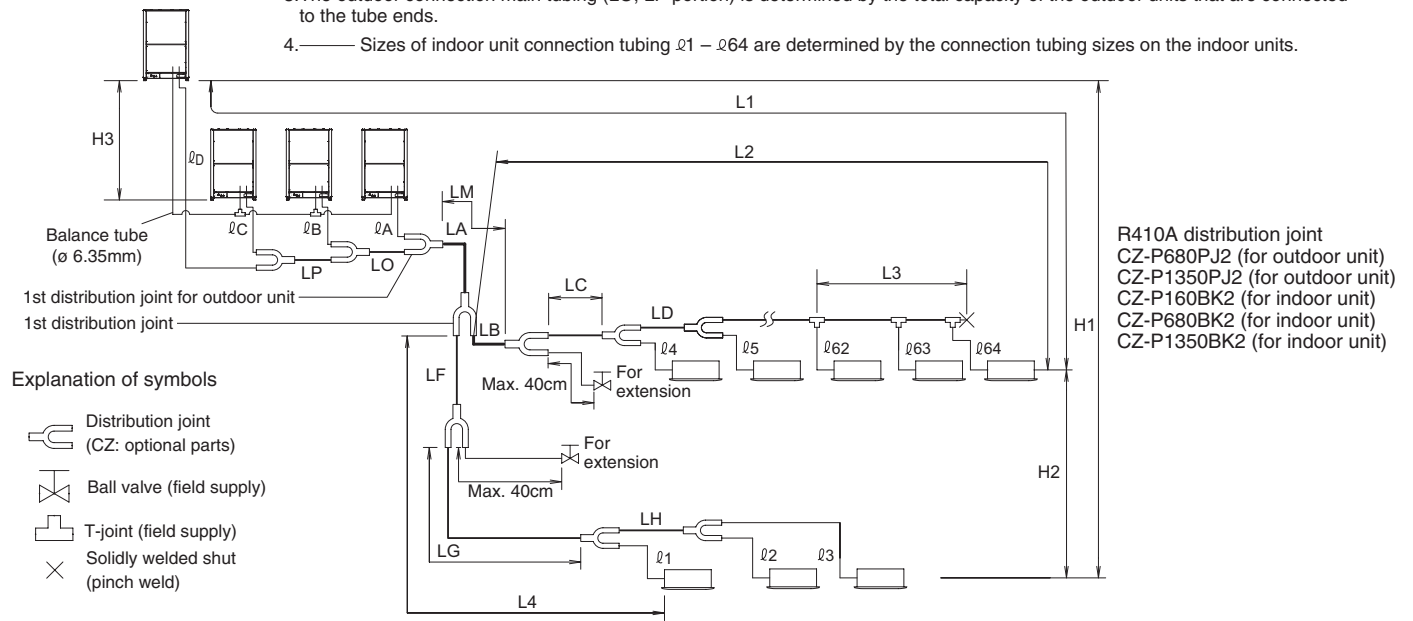

NOTE Use special R410A distribution joints (CZ: optional parts) for outdoor unit connections and tubing branches.

Table 2 Ranges that Apply to Refrigerant Tubing Lengths and to Differences in Installation Heights

Item	Mark	Contents	Length	
Allowable tubing length	L1	Max. tubing length	Actual length	$\leq 200^{*2}$
			Equivalent length	$\leq 210^{*2}$
	$\Delta L (L2 - L4)$	Difference between max. length and min. length from the 1st distribution joint	$\leq 50^{*5}$	
	LM	Max. length of main tubing (maximum tubing size of gas tube and liquid tube) * Even after 1st distribution joint, LM is allowed if at maximum tubing length.	— ^{*3}	
	$\varnothing 1, \varnothing 2 \sim \varnothing 64$	Max. length of each distribution tube	$\leq 50^{*7}$	
	$L1 + \varnothing 1 + \varnothing 2 + \dots + \varnothing 63 + \varnothing A + \varnothing B + \varnothing C + \varnothing F + \varnothing G + \varnothing H$	Total max. tubing length including length of each distribution tube (only liquid tubing)	≤ 1000	
Allowable elevation difference	H1	When outdoor unit is installed higher than indoor unit	≤ 50	
		When outdoor unit is installed lower than indoor unit	≤ 40	
	H2	Max. difference between indoor units	$\leq 15^{*6}$	
	H3	Max. difference between outdoor units	≤ 4	
Allowable length of joint tubing	L3	T-joint tubing (field-supply); Max. tubing length between the first T-joint and solidly welded-shut end point	≤ 2	

L^*, \varnothing^* = Length H^* = Height

NOTE

- 1: The outdoor connection main tubing (LO, LP portion) is determined by the total capacity of the outdoor units that are connected to the tube ends.
- 2: If the longest tubing length ($L1$) exceeds 90 m (equivalent length), increase the sizes of the main tubes (LM) by 1 rank for gas tubes and liquid tubes. Use a field supply reducer. Select the tube size from the table of main tubing sizes (Table 3) and from the table of refrigerant tubing sizes (Table 8).
- 3: If the longest main tubing length (LM) exceeds 50 m, increase the main tubing size at the portion before 50 m by 1 rank for the gas tubes. Use a field supply reducer. Determine the length less than the limitation of allowable maximum tubing length. For the portion that exceeds 50 m, set based on the main tubing size (LA) listed in Table 3.
- 4: If the size of the existing tubing is already larger than the standard tubing size, it is not necessary to further increase the size.

* If the existing tubing is used, and the amount of on-site refrigerant charge exceeds the value listed below, then change the size of the tubing to reduce the amount of refrigerant.

- Total amount of refrigerant for the system with 1 outdoor unit: 50 kg
- Total amount of refrigerant for the system with 2 outdoor units: 80 kg
- Total amount of refrigerant for the system with 3 outdoor units or 4 outdoor units: 105 kg

- 5: When the tubing length exceeds 40 m, increase a longer liquid and gas tubing by 1 rank.
Refer to the Technical Data for the details.
- 6: If the total distribution tubing length exceeds 500m, maximum allowable elevation difference (H2) between the indoor units is calculated by the following formula. Make sure the indoor unit's actual elevation difference should fall within the figure calculated as follows.
Unit of account (meter): $15 \times (2 - \text{total tubing length(m)} \div 500)$
- 7: If any of the tubing length exceeds 30m, increase the size of the liquid and gas tubes by 1 rank.

1-6. Tubing Size

■ Table 3 Main Tubing Size (LA)

Unit: mm

kW	22.4	28.0	33.5	40.0	45.0	50.0	56.0	61.5	68.0	73.0	78.5	85.0	90.0	96.0
Total system horsepower	8	10	12	14	16	18	20	22	24	26	28	30	32	34
Combined outdoor units	8	10	12	14	16	18	20	12 10	12 12	16 10	16 12	16 14	16 16	20 14
Gas tube	ø19.05	ø22.22	ø25.4		ø28.58				ø31.75					
Liquid tube	ø9.52		ø12.7			ø15.88				ø19.05				

kW	101.0	107.0	113.0	118.0	124.0	130.0	135.0	140.0	145.0	151.0	156.0	162.0	168.0	174.0
Total system horsepower	36	38	40	42	44	46	48	50	52	54	56	58	60	62
Combined outdoor units	20 16	20 18	20 20	16 16 10	16 16 12	16 16 14	16 16 16	20 16 14	20 16 16	20 20 14	20 20 16	20 20 18	20 20 20	16 16 16 14
Gas tube	ø38.10													ø41.28
Liquid tube	ø19.05													

kW	180.0	185.0	190.0	196.0	202.0	208.0	213.0	219.0	224.0
Total system horsepower	64	66	68	70	72	74	76	78	80
Combined outdoor units	16 16 16	20 20 16 10	20 20 16 12	20 20 20 10	20 20 16 16	20 20 18 16	20 20 20 16	20 20 20 18	20 20 20 20
Gas tube	ø41.28				ø44.45				
Liquid tube	ø19.05		ø22.22						

- * If future extension is planned, select the tubing diameter based on the total horsepower after extension. However, extension is not possible if the resulting tubing size is two ranks higher.
- * The balance tube (outdoor unit tube) diameter is ø6.35.
- * The refrigerant tubing should be used with R410A refrigerant.
- * If the length of the longest tube (L1) exceeds 90 m (equivalent length), increase the main tubing (LM) size by 1 rank for the gas and liquid tubes. Select from Table 3 and Table 8. Use field-supply reducers. If the tube diameter is more than ø41.28, use field-supply reducer.
- * If the longest main tubing length (LM) exceeds 50 m, increase the main tubing size at the portion before 50 m by 1 rank for the gas tubes.
For the portion that exceeds 50 m, set based on the main tubing size (LA) listed in the table above.

■ Size of Tubing (LO, LP) Between Outdoor Units

Calculate the total relevant horsepower connected to the tube ends of outdoor units and select the size of tubing between outdoor units based on the main tubing size (LA) listed in the table above.

■ Table 4 Main Tubing Size After Distribution (LB, LC...)

Unit: mm
HP = horsepower

Total capacity after distribution	Over kW	—	7.1 (2.5 HP)	16.0 (6 HP)	22.5 (8.1 HP)	30.0 (11 HP)	42.0 (15 HP)	52.4 (19 HP)	70.0 (25 HP)	98.0 (35 HP)	170.0 (61 HP)	187.0 (67 HP)	199.0 (71 HP)
	Below kW	7.1 (2.5 HP)	16.0 (6 HP)	22.5 (8.1 HP)	30.0 (11 HP)	42.0 (15 HP)	52.4 (19 HP)	70.0 (25 HP)	98.0 (35 HP)	170.0 (61 HP)	187.0 (67 HP)	199.0 (71 HP)	—
Tubing size	Gas tube	ø12.7	ø15.88	ø19.05	ø22.22	ø25.4	ø28.58	ø28.58	ø31.75	ø38.1	ø41.28	ø41.28	ø44.45
	Liquid tube	ø9.52	ø9.52	ø9.52	ø9.52	ø12.7	ø12.7	ø15.88	ø19.05	ø19.05	ø19.05	ø22.22	ø22.22

Note: In case the total capacity of indoor units connected after distribution exceeds the total capacity of the outdoor units, select the main tubing size for the total capacity of the outdoor units.

■ Table 5 Outdoor Unit Tubing Connection Size (∅A – ∅D)

Unit: mm

kW	22.4	28.0	33.5	40.0	45.0	50.0	56.0
Horsepower (HP)	8	10	12	14	16	18	20
Gas tube	∅19.05	∅22.22	∅25.4		∅28.58		
	Braze connection						
Liquid tube	∅9.52		∅12.7			∅15.88	
	Flare connection						
Balance tube	∅6.35						
	Flare connection						

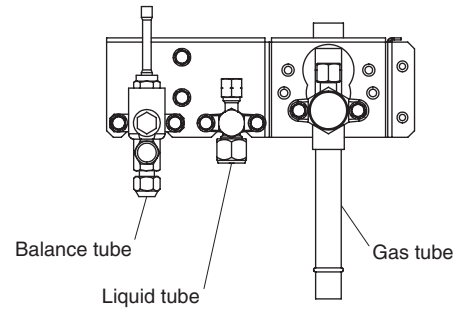

■ Table 6 Indoor Unit Tubing Connection Size

Indoor unit type	22	28	36	45	56	60	73	90	106	140	160	180	224	280
Gas tube (mm)	∅12.7					∅15.88						∅19.05		∅22.22
Liquid tube (mm)	∅6.35					∅9.52								

Note: Use the material of temper - 1/2 H or - H for tubing over ∅22.22.

1-7. Straight Equivalent Length of Joints

Design the tubing system by referring to the following table for the straight equivalent length of joints.

Table 7 Straight Equivalent Length of Joints

Gas tubing size (mm)	12.7	15.88	19.05	22.22	25.4	28.58	31.8	38.1	41.28	44.45	50.8
90° elbow	0.30	0.35	0.42	0.48	0.52	0.57	0.70	0.79	0.85	0.92	1.00
45° elbow	0.23	0.26	0.32	0.36	0.39	0.43	0.53	0.59	0.64	0.69	0.79
U-shape tube bent (R60-100 mm)	0.90	1.05	1.26	1.44	1.56	1.71	2.10	2.37	2.55	2.76	3.00
Trap bend	2.30	2.80	3.20	3.80	4.30	4.70	5.00	5.80	6.80	7.40	7.98
Y-branch distribution joint	Equivalent length conversion not needed.										
Ball valve for service	Equivalent length conversion not needed.										

Table 8 Refrigerant Tubing

Tubing size (mm)			
Material Temper - O		Material Temper - 1/2 H • H	
∅6.35	t0.8	∅22.22	t1.0
∅9.52	t0.8	∅25.4	t1.0
∅12.7	t0.8	∅28.58	t1.0
∅15.88	t1.0	∅31.75	t1.1
∅19.05	t1.2	∅38.1	over t1.35
		∅41.28	over t1.45
		∅44.45	over t1.55
		∅50.8	over t1.8

* When bending the tubes, use a bending radius that is at least 4 times the outer diameter of the tubes. In addition, take sufficient care to avoid crushing or damaging the tubes when bending them.

1-8. Additional Refrigerant Charge

Additional refrigerant charge amount is calculated below.

$$\text{Required amount of additional refrigerant charge} = [(\text{Amount of additional refrigerant charge per meter of each size of liquid tube} \times \text{its tube length}) + (\dots) + (\dots)] + [(\text{Necessary amount of additional refrigerant charge per outdoor unit}) + (\dots) + (\dots)]$$

*Always charge accurately using a scale for weighing.

*If the existing tubing is used and the amount of on-site refrigerant charge exceeds the value listed below, change the size of the tubing to reduce the amount of refrigerant.

Total amount of refrigerant for the system with 1 outdoor unit: 50 kg

Total amount of refrigerant for the system with 2 outdoor units: 80 kg

Total amount of refrigerant for the system with 3 outdoor units or 4 outdoor units: 105 kg

Table 9 Amount of Additional Refrigerant Charge Per Meter, According to Liquid Tubing Size

Liquid tubing size (mm)	6.35	9.52	12.7	15.88	19.05	22.22	25.4
Amount of additional refrigerant charge/m (g/m)	26	56	128	185	259	366	490

Table 10 Necessary Amount of Additional Refrigerant Charge Per Outdoor Unit

U-8ME2R8(E)	U-10ME2R8(E)	U-12ME2R8(E)	U-14ME2R8(E)	U-16ME2R8(E)	U-18ME2R8(E)	U-20ME2R8(E)
—	—	4.0 kg	4.0 kg	4.0 kg	5.5 kg	5.5 kg

Table 11 Refrigerant Charge Amount at Shipment (for Outdoor Unit)

U-8ME2R8(E)	U-10ME2R8(E)	U-12ME2R8(E)	U-14ME2R8(E)	U-16ME2R8(E)	U-18ME2R8(E)	U-20ME2R8(E)
11.1 kg	11.1 kg	11.3 kg	11.3 kg	11.3 kg	11.0 kg	11.0 kg

1-9. System Limitations

Table 12 System Limitations

Max. No. allowable connected outdoor units	4 *2
Max. capacity allowable connected outdoor units	224 kW (80 HP)
Max. connectable indoor units	64 *1
Max. allowable indoor/outdoor capacity ratio	50 – 130 %*3

- *1: In the case of 38 HP or smaller units, the number is limited by the total capacity of the connected indoor units.
- *2: Up to 4 units can be connected if the system has been extended.
- *3: If the following conditions are satisfied, the effective range is above 130 % and below 200 %.
 - i) Obey the limited number of connectable indoor units.
 - ii) The lower limit of operating range for heating outdoor temperature is limited to -10°CWB (standard -25°CWB).
 - iii) Simultaneous operation is limited to less than 130 % of connectable indoor units.

Maximum number of connectable indoor units when connected with minimum capacity

Total horse power	Number of indoor units	Total horse power	Number of indoor units	Total horse power	Number of indoor units	Total horse power	Number of indoor units	Total horse power	Number of indoor units	Total horse power	Number of indoor units
8 HP	13	14 HP	23	20 HP	33	26 HP	43	32 HP	53	38 HP	63
10 HP	16	16 HP	26	22 HP	36	28 HP	46	34 HP	56	40-80 HP	64
12 HP	19	18 HP	29	24 HP	40	30 HP	50	36 HP	59		

WARNING Always check the gas density limit for the room in which the unit is installed.

1-10. Check of Limit Density

When installing an air conditioner in a room, it is necessary to ensure that even if the refrigerant gas accidentally leaks out, its density does not exceed the limit level for that room. If the density could exceed the limit level, it is necessary to provide an opening between the unit and the adjacent room, or to install mechanical ventilation which is interlocked with a leak detector.

(Total refrigerant charged amount: kg)

(Min. indoor volume where the indoor unit is installed: m³)

≤ Limit density 0.44 (kg/m³)

The limit density of refrigerant R410A which is used in this unit is 0.44 kg/m³ (ISO 5149).

The shipped outdoor unit comes charged with the amount of refrigerant fixed for each type, so add it to the amount that is charged in the field. (For the refrigerant charge amount at shipment, refer to the unit's nameplate.)

Minimum indoor volume & floor area as against the amount of refrigerant is roughly as given in the following table.

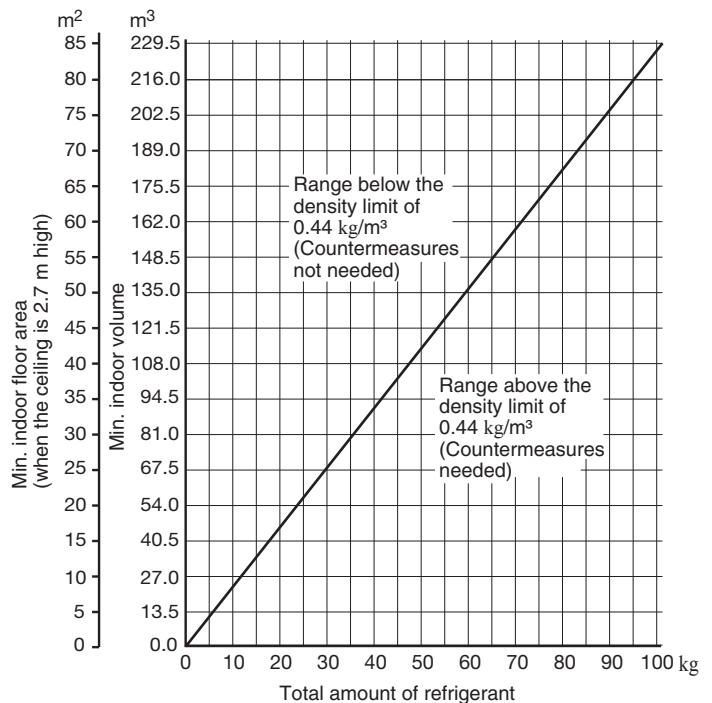

CAUTION Pay special attention to any location, such as a basement, etc., where leaking refrigerant can accumulate, since refrigerant gas is heavier than air.

1-11. Installing Distribution Joint

(1) Refer to "HOW TO ATTACH DISTRIBUTION JOINT" enclosed with the optional distribution joint kit (CZ-P680PJ2, CZ-P1350PJ2, CZ-P160BK2, CZ-P680BK2, CZ-P1350BK2).

- When connecting a branch tubing to the indoor unit directly, it is necessary for each branch tubing to install at a positive angle with respect to horizontal in order to prevent accumulation of refrigerant oil in stopped units. See the below chart.

Branch tubing system **—** Restricted **- - - - -** Not restricted

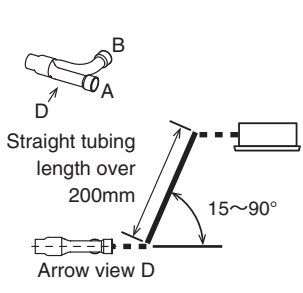
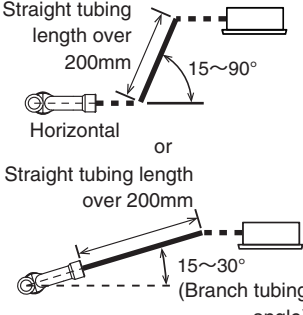
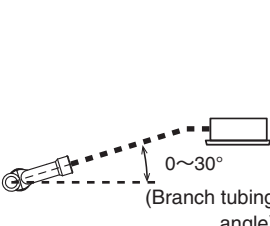
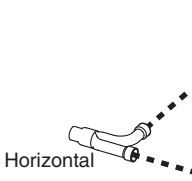
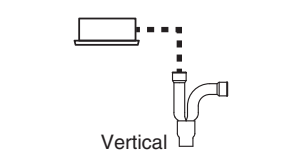
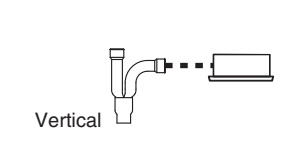
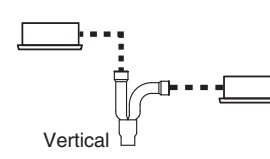
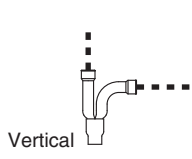
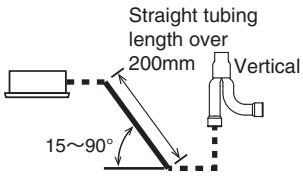
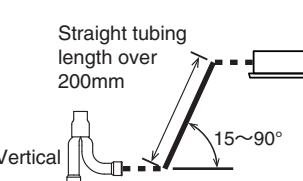
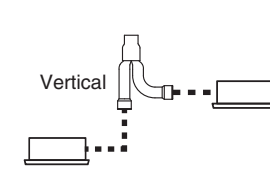
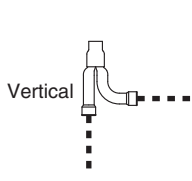
How to install branch tubing 	When connecting branch tubing to indoor unit directly			When not connecting branch tubing to indoor unit directly	
	Gas tube		Liquid tube		Gas & liquid tubes
	When connecting to A	When connecting to B			
Horizontal					
Vertical	Upward				
	Downward				

Header branch system (Main tubing is horizontal.)

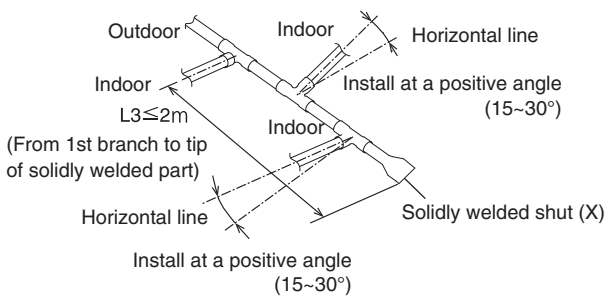

- Be sure to solidly weld shut the T-joint end (marked by X in the figure). In addition, pay attention to the insertion depth of each connected tube so that the flow of refrigerant within the T-joint is not impeded. Be sure to use a commercial available T-joint.
- When using the header joint system, do not make further branches in the tubing.
- Do not use the header joint system on the outdoor unit side.

1-12. Optional Distribution Joint Kits

See the installation instructions packaged with the distribution joint kit for the installation procedure.

Table 13

Model name	Cooling capacity after distribution	Remarks	Model name	Cooling capacity after distribution	Remarks
1. CZ-P680PJ2	68.0 kW or less	For outdoor unit	3. CZ-P160BK2	22.4 kW or less*	For indoor unit
2. CZ-P1350PJ2	more than 68.0 kW	For outdoor unit	4. CZ-P680BK2	68.0 kW or less*	For indoor unit
			5. CZ-P1350BK2	more than 68.0 kW *	For indoor unit

*In case the total capacity of indoor units connected after distribution exceeds the total capacity of the outdoor units, select the distribution tubing size for the total capacity of the outdoor units.

■ Tubing size (with thermal insulation)

1. CZ-P680PJ2

For outdoor unit (Capacity after distribution joint is 68.0 kW or less.)

Example:

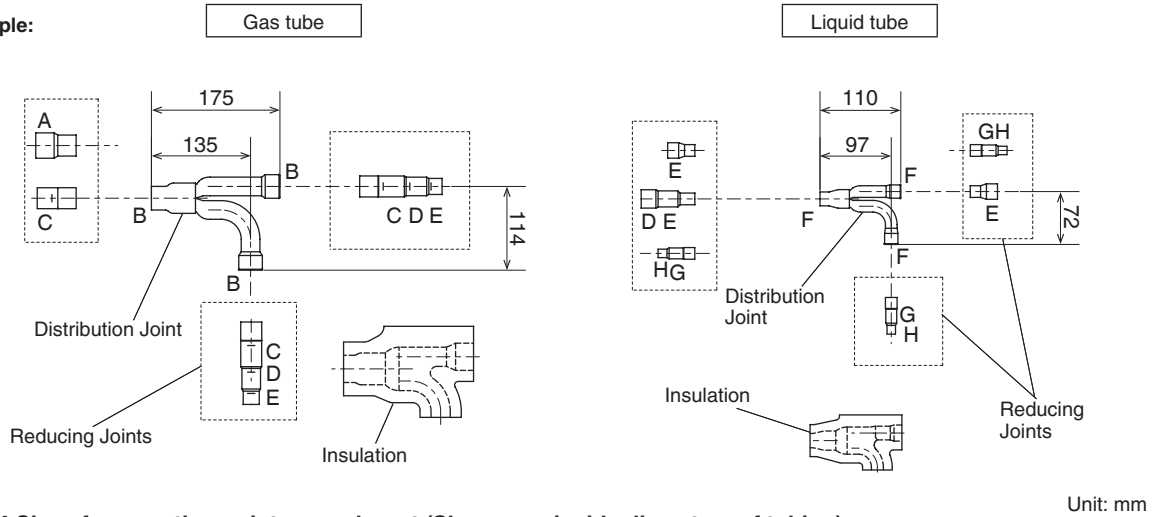

Table 14 Size of connection point on each part (Shown are inside diameters of tubing)

Size	Part A	Part B	Part C	Part D	Part E	Part F	Part G	Part H
mm	ø31.75	ø28.58	ø25.4	ø22.22	ø19.05	ø15.88	ø12.7	ø9.52

2. CZ-P1350PJ2

For outdoor unit (Capacity after distribution joint is more than 68.0 kW.)

Example:

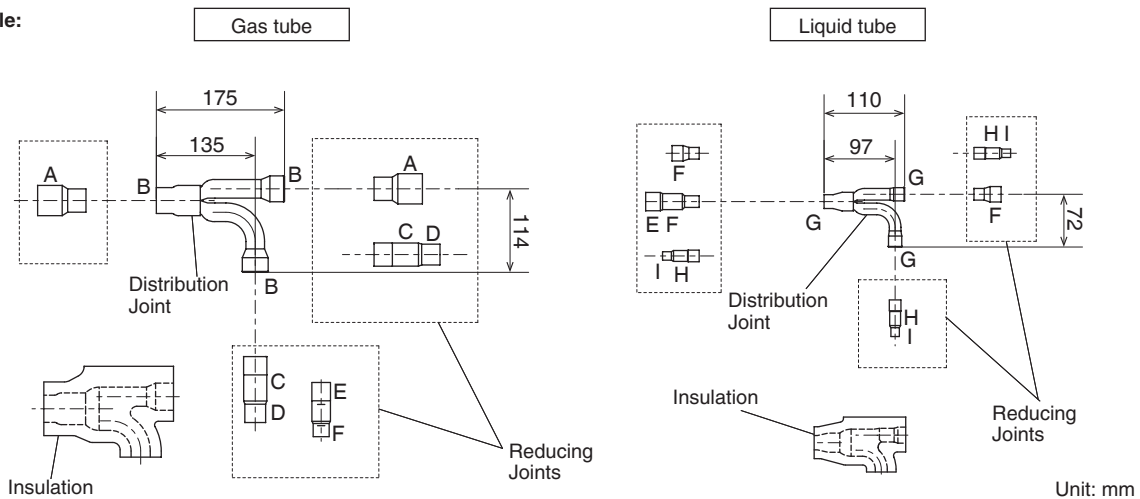

*If the tube diameter is more than ø38.1, use field-supply reducer.

Table 15 Size of connection point on each part (Shown are inside diameters of tubing)

Size	Part A	Part B	Part C	Part D	Part E	Part F	Part G	Part H	Part I
mm	ø38.1	ø31.75	ø28.58	ø25.4	ø22.22	ø19.05	ø15.88	ø12.7	ø9.52

3. CZ-P160BK2

Use: For indoor unit (Capacity after distribution joint is 22.4 kW or less.)*

Example:

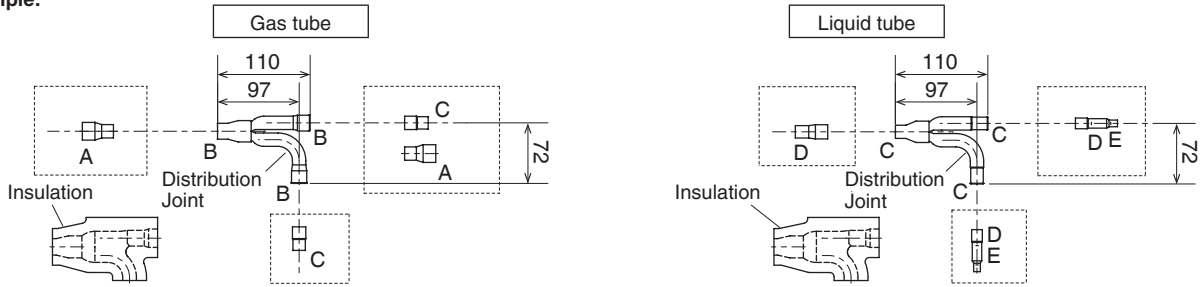

Unit: mm

Table 16 Size of connection point on each part (Shown are inside diameters of tubing)

Size	Part A	Part B	Part C	Part D	Part E
mm	ø19.05	ø15.88	ø12.7	ø9.52	ø6.35

4. CZ-P680BK2

Use: For indoor unit (Capacity after distribution joint is more than 22.4 kW and no more than 68.0 kW.)*

Example:

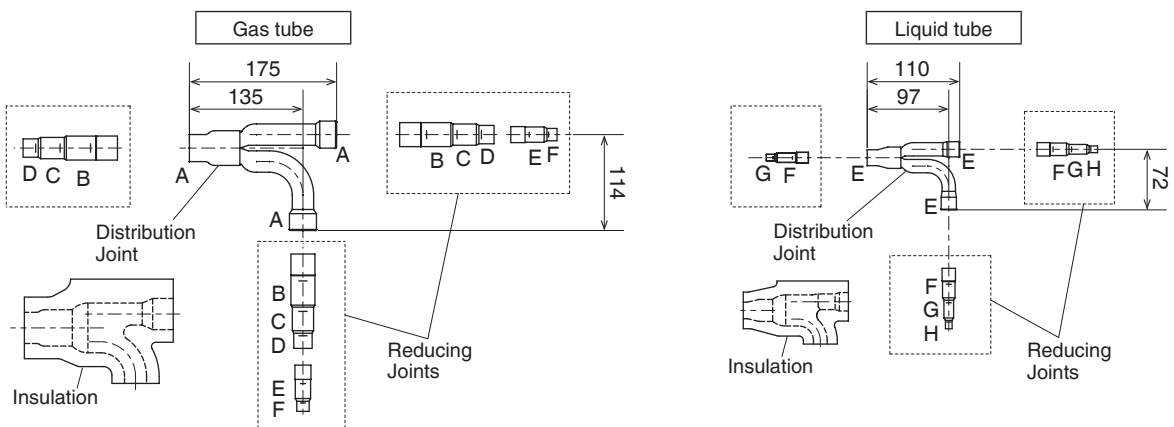

Unit: mm

Table 17 Size of connection point on each part (Shown are inside diameters of tubing)

Size	Part A	Part B	Part C	Part D	Part E	Part F	Part G	Part H
mm	ø28.58	ø25.4	ø22.22	ø19.05	ø15.88	ø12.7	ø9.52	ø6.35

5. CZ-P1350BK2

Use: For indoor unit (Capacity after distribution joint is more than 68.0 kW.)*

Example:

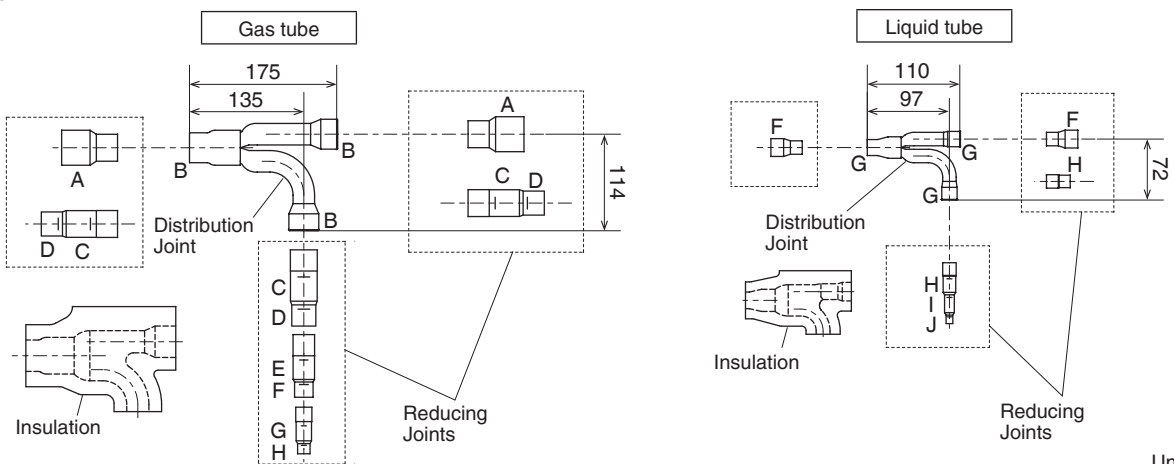

Unit: mm

*If the tube diameter is more than ø38.1, use field-supply reducer.

*If the tube diameter is more than ø19.05, use field-supply reducer.

Table 18 Size of connection point on each part (Shown are inside diameters of tubing)

Size	Part A	Part B	Part C	Part D	Part E	Part F	Part G	Part H	Part I	Part J
mm	ø38.1	ø31.75	ø28.58	ø25.4	ø22.22	ø19.05	ø15.88	ø12.7	ø9.52	ø6.35

*In case the total capacity of indoor units connected after distribution exceeds the total capacity of the outdoor units, select the distribution tubing size for the total capacity of the outdoor units.

1-13. Example of Tubing Size Selection and Refrigerant Charge Amount

Additional refrigerant charging

Based on the values in Tables 3, 4, 5, 6, 9 and 10, use the liquid tubing size and length, and calculate the amount of additional refrigerant charge using the formula below.

Required additional refrigerant charge (kg)	$= [490 \times (a) + 366 \times (b) + 259 \times (c) + 185 \times (d) + 128 \times (e) + 56 \times (f) + 26 \times (g)] \times 10^{-3} + \text{Necessary amount of additional refrigerant charge per outdoor unit.}$
---	--

- (a) : Liquid tubing Total length of $\phi 25.4$ (m)
- (b) : Liquid tubing Total length of $\phi 22.22$ (m)
- (c) : Liquid tubing Total length of $\phi 19.05$ (m)
- (d) : Liquid tubing Total length of $\phi 15.88$ (m)
- (e) : Liquid tubing Total length of $\phi 12.7$ (m)
- (f) : Liquid tubing Total length of $\phi 9.52$ (m)
- (g) : Liquid tubing Total length of $\phi 6.35$ (m)

● Charging procedure

Be sure to charge with R410A refrigerant **in liquid form**.

1. After performing a vacuum, charge with refrigerant from the liquid tubing side. At this time, all valves must be in the “fully closed” position.
2. If not charged as prescribed amount, charge from the refrigerant charge connection port while operating in the cooling mode. (This is performed at the time of the test run. For this, all valves must be in the “fully open” position. However if only one outdoor unit is installed, a balance tube is not used. Therefore, leave the valves fully closed.)

Charge with R410A refrigerant in liquid form.

With R410A refrigerant, charge while adjusting the amount being fed a little at a time in order to prevent liquid refrigerant from backing up.

- After charging is completed, turn all valves to the “fully open” position.
- Replace the tubing covers as they were before.

1. **R410A additional charging absolutely must be done through liquid charging.**
2. **The R410A refrigerant cylinder has a gray base color, and the top part is pink.**
3. **The R410A refrigerant cylinder includes a siphon tube. Check that the siphon tube is present. (This is indicated on the label at the top of the cylinder.)**
4. **Due to differences in the refrigerant, pressure, and refrigerant oil involved in installation, it is not possible in some cases to use the same tools for R22 and for R410A.**



CAUTION

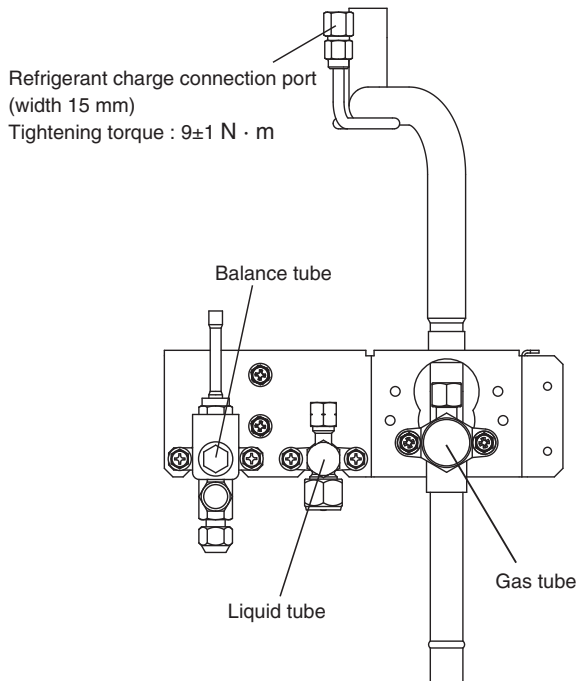

* Use a hexagonal wrench and turn to the left to open.

		Gas tube	Liquid tube
Hex wrench width	8 HP	5 mm	4 mm
	10 HP		
	12 HP		
	14 HP	8 mm	
	16 HP		
	18 HP		
20 HP	6 mm		

Balance tube

Rotate 90 degrees counterclockwise for OPEN

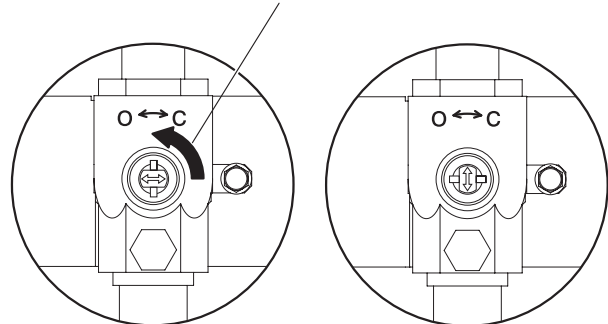

Fully closed (at shipment)

Fully open

How to turn the tab

Example:

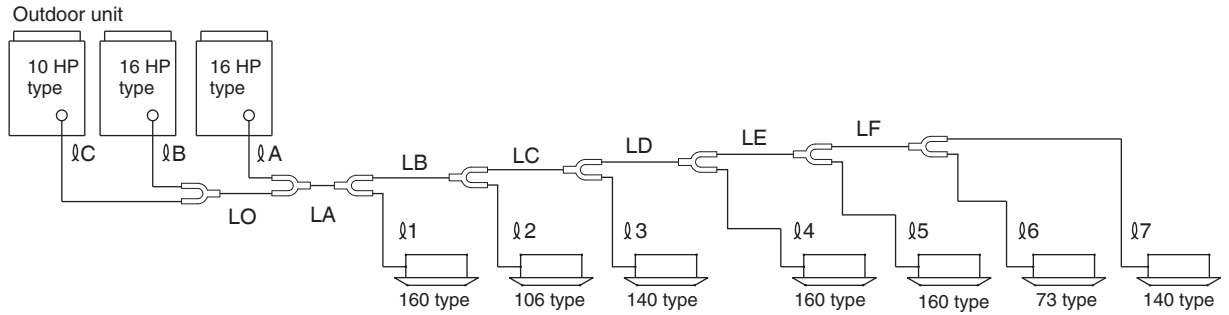

● Example of each tubing length

Main tubing

LO = 2 m
 LA = 40 m
 LB = 5 m
 LC = 5 m

Distribution joint tubing

Outdoor side	Indoor side
l A = 2 m	l 1 = 30 m l 5 = 2 m
l B = 2 m	l 2 = 5 m l 6 = 6 m
l C = 3 m	l 3 = 5 m l 7 = 5 m
	l 4 = 5 m

Note :The maximum tubing length (equivalent length) exceeds 90 m.

● Obtain liquid tubing size from Tables 3, 4, 5, 6 and 9.

Main tubing

LO = ϕ 19.05 mm (Total capacity of outdoor unit is 73.5 kW)	LD = ϕ 15.88 mm (Total capacity of indoor unit is 53.3 kW)
LA* = ϕ 22.22 mm (Total capacity of outdoor unit is 118.0 kW)	LE = ϕ 12.7 mm (Total capacity of indoor unit is 37.3 kW)
LB = ϕ 19.05 mm (Total capacity of indoor unit is 77.9 kW)	LF = ϕ 9.52 mm (Total capacity of indoor unit is 21.3 kW)
LC = ϕ 15.88 mm (Total capacity of indoor unit is 67.3 kW)	

The longest main tubing length in this example (LM = 40 + 5 = 45 m)
 * The tubing size ϕ 19.05 was increased to ϕ 22.22.

Distribution joint tubing

Outdoor side	l A: ϕ 12.7	l B: ϕ 12.7	l C: ϕ 9.52 (from outdoor unit connection tubing)
Indoor side	l 1: ϕ 9.52	l 2: ϕ 9.52	l 3: ϕ 9.52 l 4: ϕ 9.52
	l 5: ϕ 9.52	l 6: ϕ 9.52	l 7: ϕ 9.52 (from indoor unit connection tubing)

● Obtain additional charge amount.

Note 1*

The charge amounts per 1 meter are different for each liquid tubing size.

ϕ 22.22 → LA	: 40 m × 0.366 kg/m = 14.640
ϕ 19.05 → LB + LO	: 7 m × 0.259 kg/m = 1.813
ϕ 15.88 → LC + LD	: 20 m × 0.185 kg/m = 3.7
ϕ 12.7 → LE + l A + l B	: 14 m × 0.128 kg/m = 1.792
ϕ 9.52 → l C + LF + (l 1 - l 7)	: 71 m × 0.056 kg/m = 3.976

Total 25.921 kg

Note 2*

Necessary amount of additional refrigerant charge per outdoor unit (See the Table 10.)

Amount of additional charge per outdoor unit :	U-10ME2R8(E)	–	kg
	U-16ME2R8(E)	4.0	kg
	U-16ME2R8(E)	4.0	kg

Total 8.0 kg

Therefore,

*Note 1 : Amount of additional charge per tubing length : 25.921 kg

*Note 2 : Amount of additional charge per outdoor unit : 8.0 kg

Therefore, the total of additional refrigerant charge amount reaches 33.921 kg.

● Obtain overall refrigerant charge amount.

Overall refrigerant charge amount of the system indicates the calculated value shown above the additional charge amount in addition to the total of the refrigerant charge amount (shown in the Table 11) at the shipment of each outdoor unit.

Refrigerant charge amount at shipment:

U-10ME2R8(E)	: 11.1	kg
U-16ME2R8(E)	: 11.3	kg
U-16ME2R8(E)	: 11.3	kg

Additional charge amount : 33.921 kg

Grand total : 67.621 kg

Therefore, overall refrigerant charge amount of the system reaches 67.621 kg.



CAUTION Be sure to check the limit density for the room in which the indoor unit is installed.

Checking of limit density

Density limit is determined on the basis of the size of a room using an indoor unit of minimum capacity.
 For instance, when an indoor unit is used in a room (floor area 15 m² × ceiling height 2.7 m = room volume 40.5 m³), the graph at right shows that the maximum overall refrigerant charge amount of limit density (0.44 kg/m³) that is not required to install a ventilation fan should be calculated as follows.

Due to the room volume,

Maximum overall refrigerant charge amount

$$\begin{aligned}
 &= (\text{room volume}) \times (\text{limit density}) \\
 &= 40.5 \text{ (m}^3\text{)} \times 0.44 \text{ (kg/m}^3\text{)} \\
 &= 17.82 \text{ kg}
 \end{aligned}$$

Overall refrigerant charge amount for this system is 67.621 (kg).
 The formula for the minimum room volume should be determined as follows.

Required minimum room volume

$$\begin{aligned}
 &= (\text{overall refrigerant charge amount}) \div (\text{limit density}) \\
 &= 67.621 \text{ (kg)} \div 0.44 \text{ (kg/m}^3\text{)} \\
 &= 153.68 \text{ (m}^3\text{)}
 \end{aligned}$$

Required minimum floor area

$$\begin{aligned}
 &= (\text{minimum room volume}) \div (\text{ceiling height}) \\
 &= 153.68 \text{ (m}^3\text{)} \div 2.7 \text{ (m)} \\
 &= 56.9 \text{ (m}^2\text{)}
 \end{aligned}$$

Therefore an opening for ventilation is required.

< Formula for computation >

Overall refrigerant charge amount for the air conditioner: kg

$$\begin{aligned}
 &= \frac{(\text{Minimum room volume for indoor unit: m}^3)}{40.5 \text{ (m}^3\text{)}} \\
 &= \frac{67.621 \text{ (kg)}}{40.5 \text{ (m}^3\text{)}} \\
 &= 1.67 \text{ (kg/m}^3\text{)} > 0.44 \text{ (kg/m}^3\text{)}
 \end{aligned}$$

Accordingly, it is necessary to install a ventilation fan for this room.

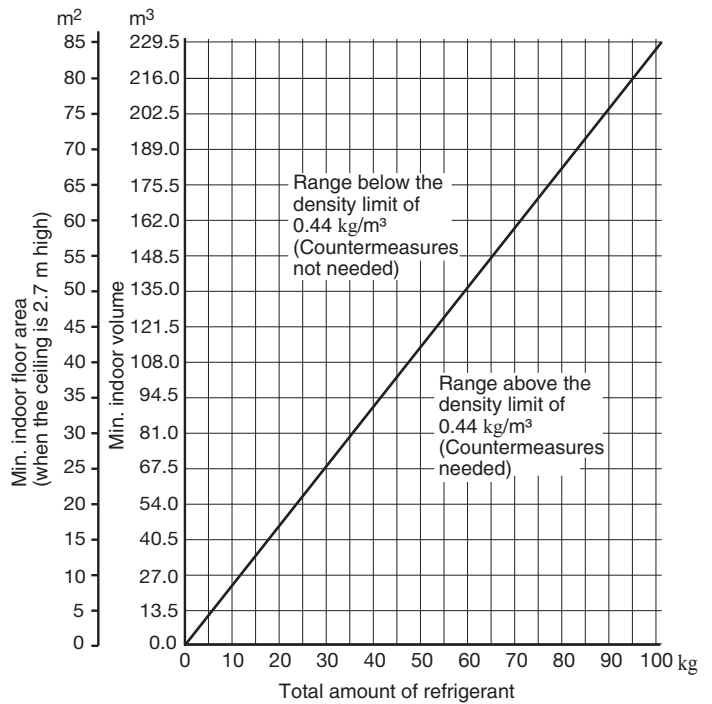

2. SELECTING THE INSTALLATION SITE

2-1. Outdoor Unit

AVOID:

- heat sources, exhaust fans, etc.
- damp, humid or uneven locations
- indoors (no-ventilation location)

DO:

- choose a place as cool as possible.
- choose a place that is well ventilated.
- allow enough room around the unit for air intake/exhaust and possible maintenance.

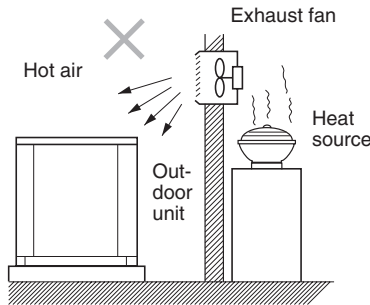

Installation Space

Install the outdoor unit where there is enough space for ventilation. Otherwise the unit may not operate properly. The figure shows the minimum space requirement around the outdoor units when 3 sides are open and only 1 side is shuttered, with open space above the unit. The mounting base should be concrete or a similar material that allows for adequate drainage. Make provisions for anchor bolts, platform height, and other site-specific installation requirements.

Example of installation of 2 units
(when 3 sides are open and only 1 side is shuttered)

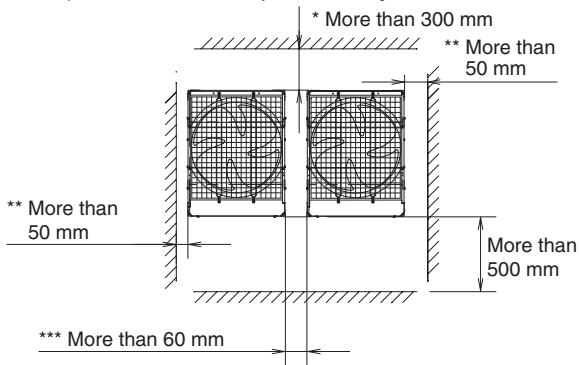

- * Make a walk-in space behind the unit to erase maintenance and servicing.
- ** When setting the anchor bolt to position "B" or "C", make the space between the unit and the wall more than 250 mm for installation operation.
- *** When setting the anchor bolt to position "B" or "C", make the space between the outdoor units more than 180 mm for installation operation.

- Leave space open above the unit.
- Construct louvers or other openings in the wall, if necessary, to ensure adequate ventilation.



NOTE

- Do not do any wiring or tubing within 30 cm of the front panel, because this space is needed as a servicing space for the compressor.
- Ensure a base height of 100 mm or more to ensure that drainage water does not accumulate and freeze around the bottom of the unit.
- If installing a drain pan, install the drain pan prior to installing the outdoor unit.
- * Make sure there is at least 150 mm between the outdoor unit and the ground.
Also, the direction of the tubing and electrical wiring should be from the front of the outdoor unit.

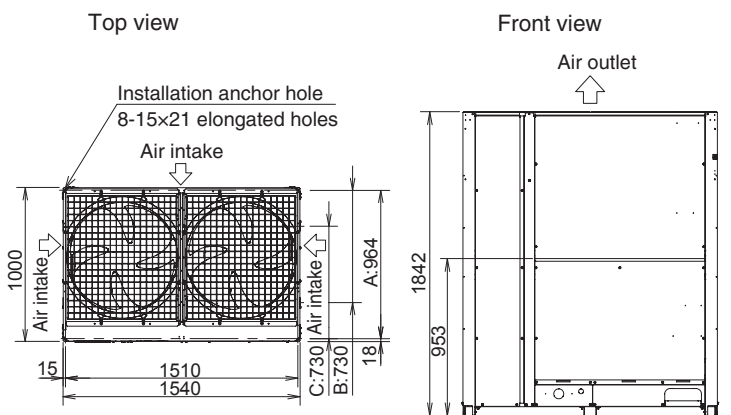
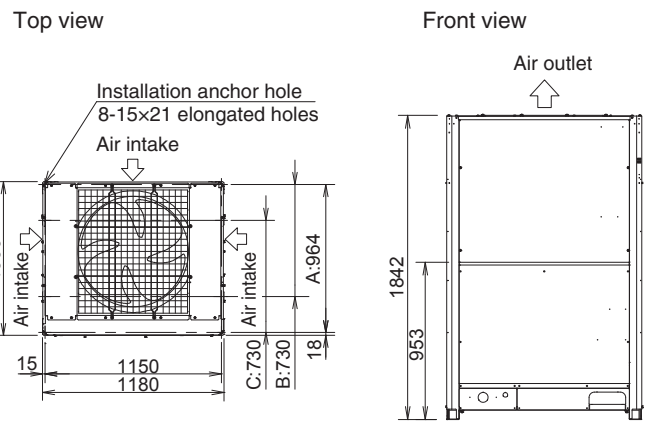
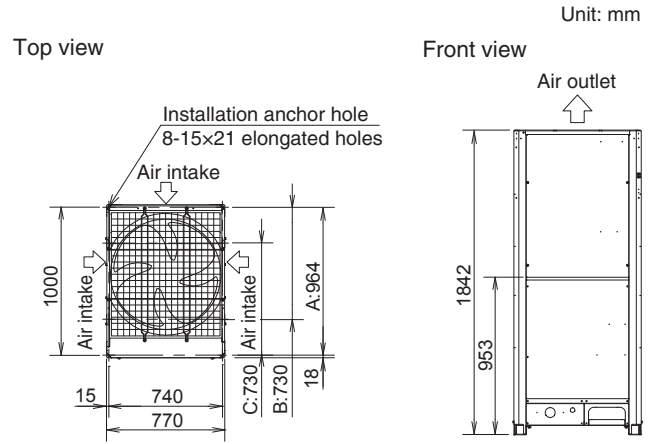

According to the installation site, you may choose the setting position in the depth direction of the anchor bolt from A, B or C.
A: (Installation hole pitch) For removing tube forward
B: (Installation hole pitch) For removing the downward
C: (Installation hole pitch)

2-2. Shield for Horizontal Exhaust Discharge

It is necessary to install an air-discharge chamber (field supply) to direct exhaust from the fan horizontally if it is difficult to provide a minimum space of 2 m between the air-discharge outlet and a nearby obstacle.

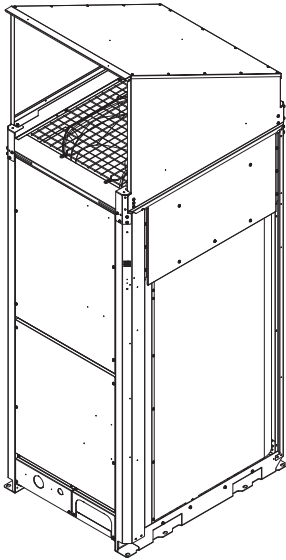

2-3. Installing the Outdoor Unit in Heavy Snow Areas

In locations where wind-blown snow can be a problem, snow-proof vents should be fitted to the unit and direct exposure to the wind should be avoided as much as possible.

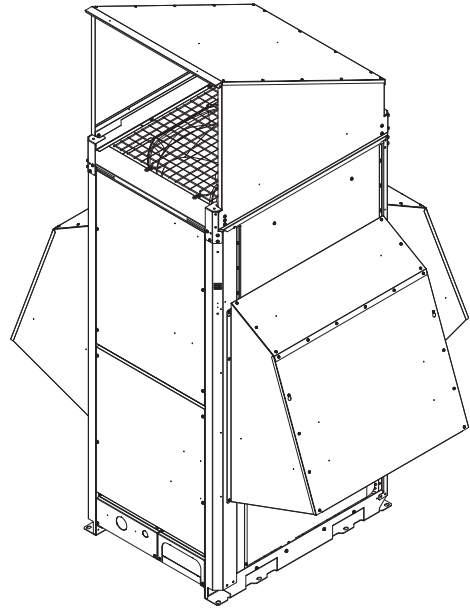

CAUTION

In regions with heavy snowfall, the outdoor unit should be provided with a solid, raised platform and snow-proof vents.

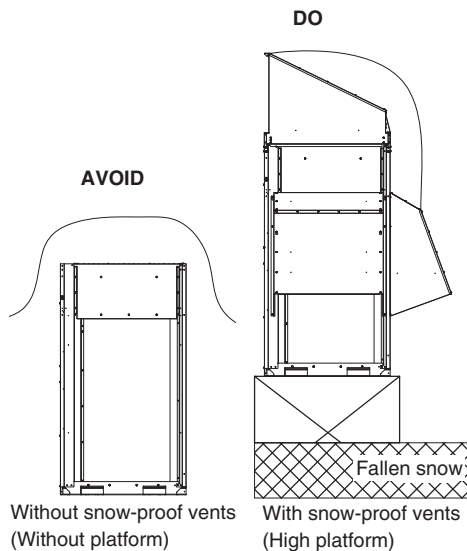

The following problems may occur if proper countermeasures are not taken:

- The fan in the outdoor unit may stop running, causing the unit to be damaged.
- There may be no air flow.
- The tubing may freeze and burst.
- The condenser pressure may drop because of strong wind, and the indoor unit may freeze.

2-4. Precautions When Installing in Heavy Snow Areas

- a) The platform should be higher than the maximum snow depth.
- b) The 2 anchoring feet of the outdoor unit should be used for the platform, and the platform should be installed beneath the air-intake side of the outdoor unit.
- c) The platform foundation must be solid and the unit must be secured with anchor bolts.
- d) When installing on a roof subject to strong wind, countermeasures must be taken to prevent the unit from being overturned.

2-5. Dimensions of Wind Ducting

Reference diagram for air-discharge chamber (field supply)

For further details, see the section "SUPPLEMENT".

2-6. Dimensions of Snow Ducting

Reference diagram for snow-proof vents (field supply)

For further details, see the section "SUPPLEMENT".

3. HOW TO INSTALL THE OUTDOOR UNIT

3-1. Transporting

When transporting the unit, have it delivered as close to the installation site as possible without unpacking. Use a hook for suspending the unit respectively according to the type of model.

CAUTION

- When hoisting the outdoor unit, pass lifting belts through the left and right holes of the bottom plate as shown in the following figures. Use two lengths of lifting belt 7.5 meters long or longer.
- Hang the lifting belt at an oblique angle of the four corners of the bottom plate. If it is hung at other areas, the lifting belt becomes loose and the outdoor unit will be damaged or you may be injured.
- Use protective panels or padding at all locations where the lifting belt contacts the outer casing or other parts to prevent scratching. In particular, use protective material (such as cloth or cardboard) to prevent the edges of the top panel from being scratched.

Model: 12 HP, 14 HP, 16 HP

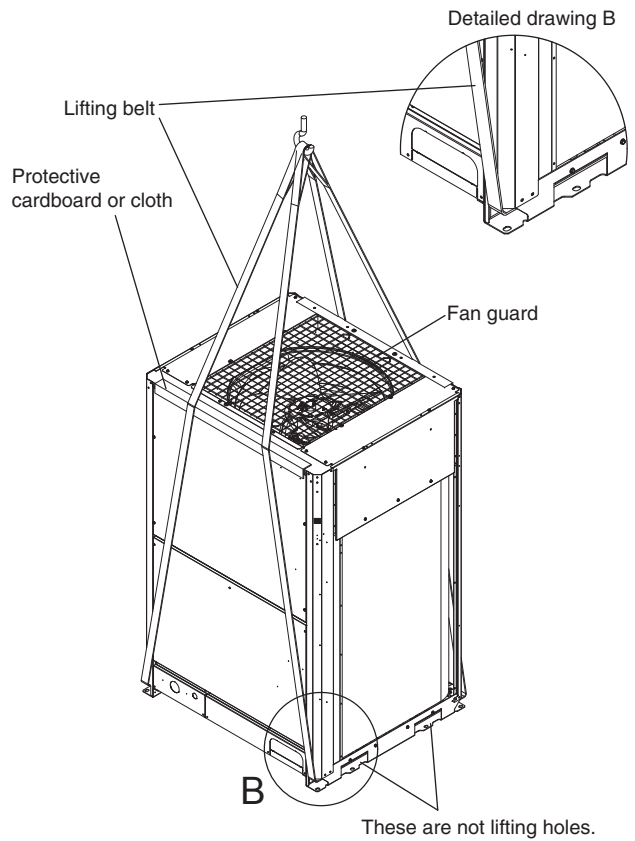

Model: 8 HP, 10 HP

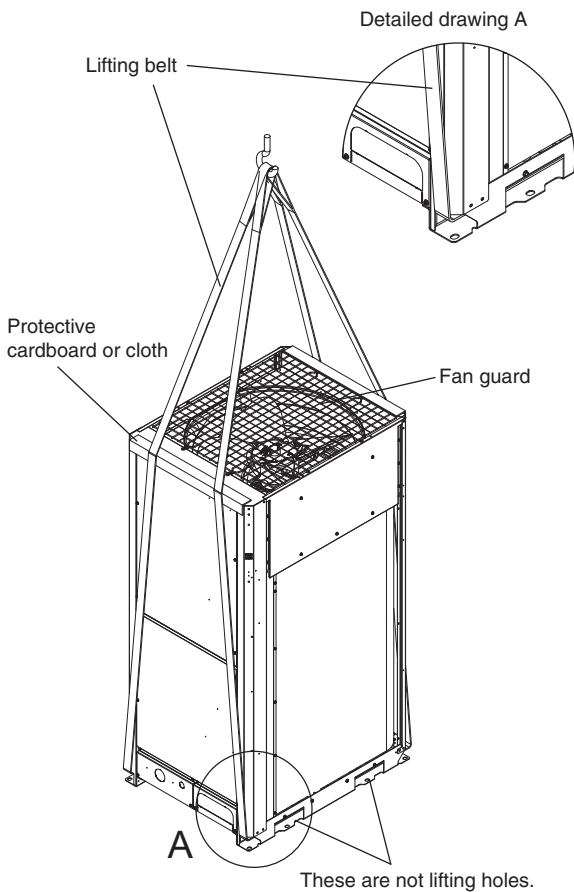

Model: 18 HP, 20 HP

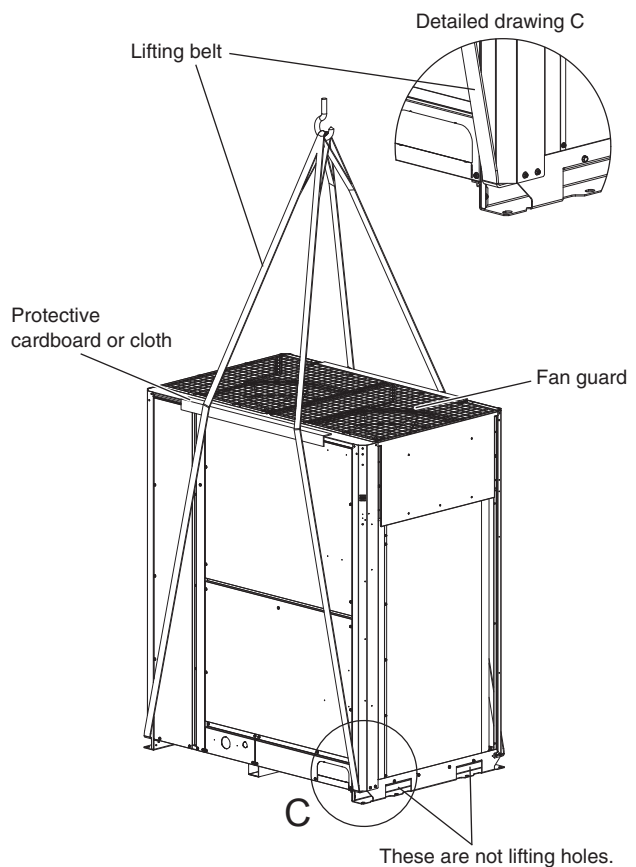

3-2. Installing the Outdoor Unit

(1) Use four anchor bolts (M12 or similar) to securely anchor the unit. Regarding the positioning anchor bolts of the depth direction, select one of three types according to the installation site as shown in the following figures. Normally, select the position A. When removing the connection tube in a downward direction, select the position B.

(2) When only using a single outdoor unit, see the figure below.

Model: 8 HP, 10 HP

Unit: mm

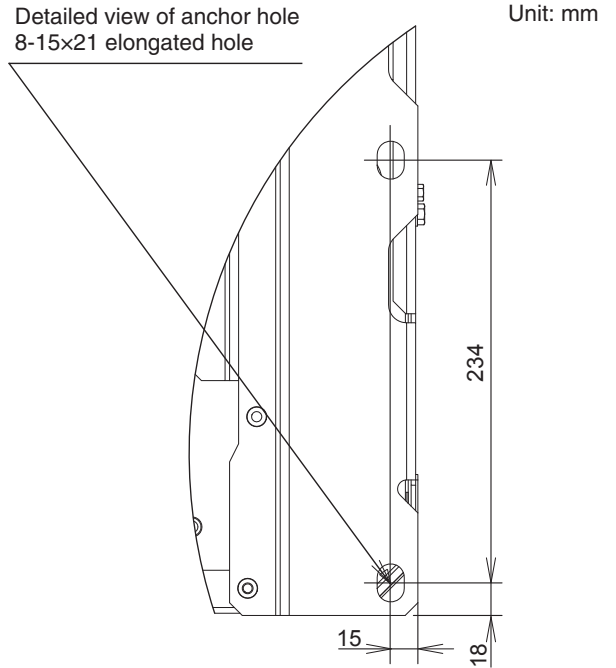
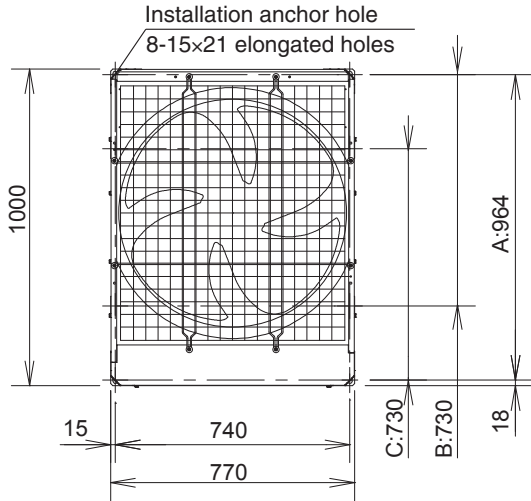

Model: 12 HP, 14 HP, 16 HP

Unit: mm

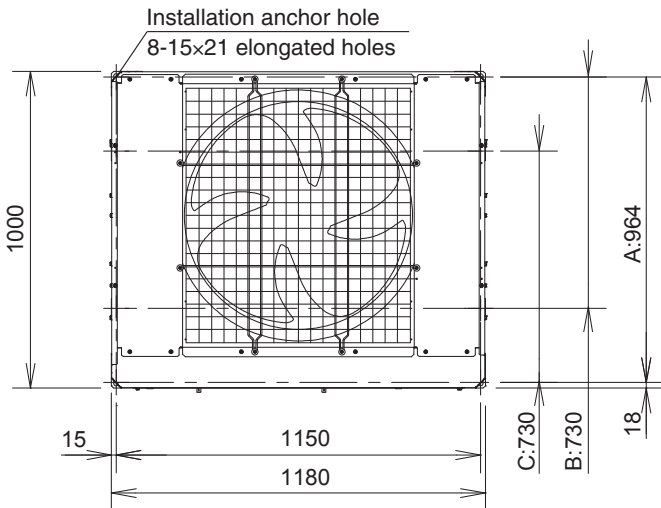

In case of the combination with different units, see the section "SUPPLEMENT".

*When positioning the anchor bolt at B or C, make a sufficient space between the units or from the wall for installation. (Make a space between the units wider than 180mm and left and right space wider than 250mm from the wall.)

(3) The vibration insulator or the like should be kept secure to satisfy the width and depth for the plate legs. Use a washer from the upper direction larger than the hole size for fixing the installation.

Model: 18 HP, 20 HP

Unit: mm

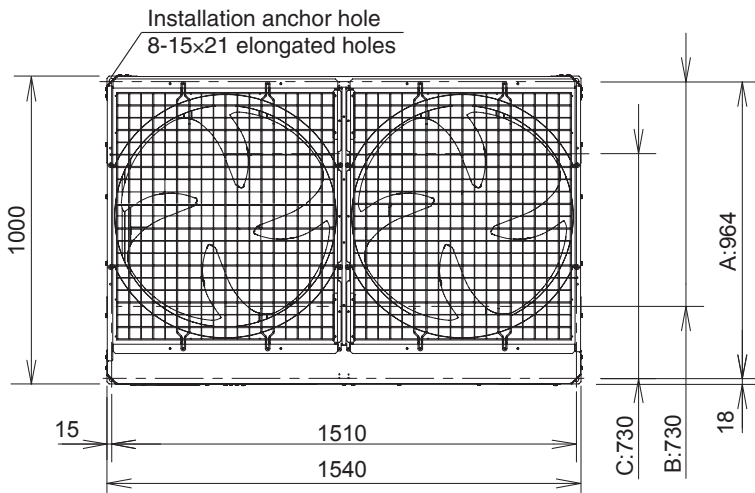

- Below shows vibration insulator position when setting anchor bolt at position A.

Model : 8 HP, 10 HP, 12 HP,
14 HP, 16 HP

Model : 18 HP, 20 HP

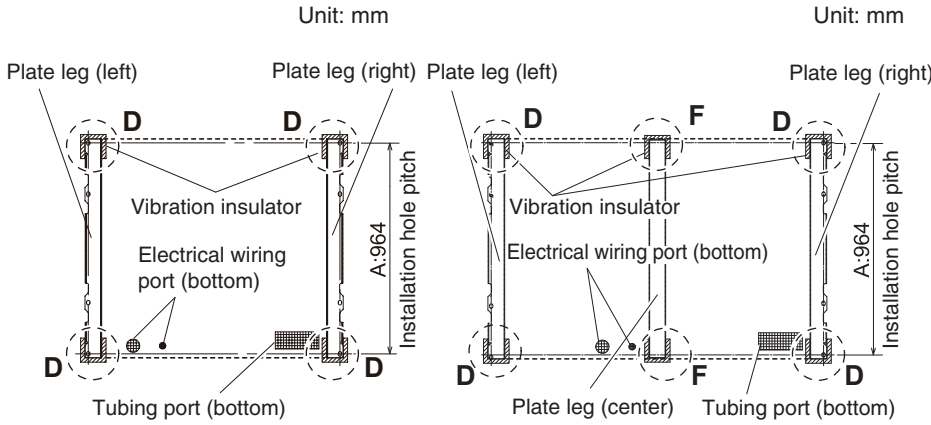

Detailed view of D and E

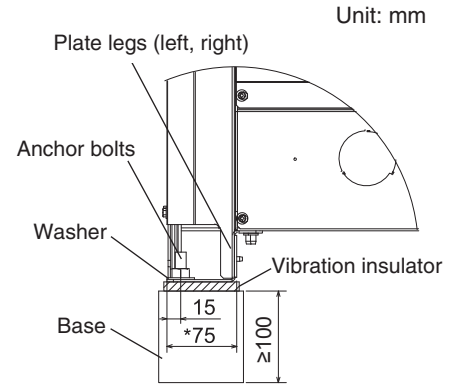

- Below shows vibration insulator position when setting anchor bolt at position B.

Model : 8 HP, 10 HP, 12 HP,
14 HP, 16 HP

Model : 18 HP, 20 HP

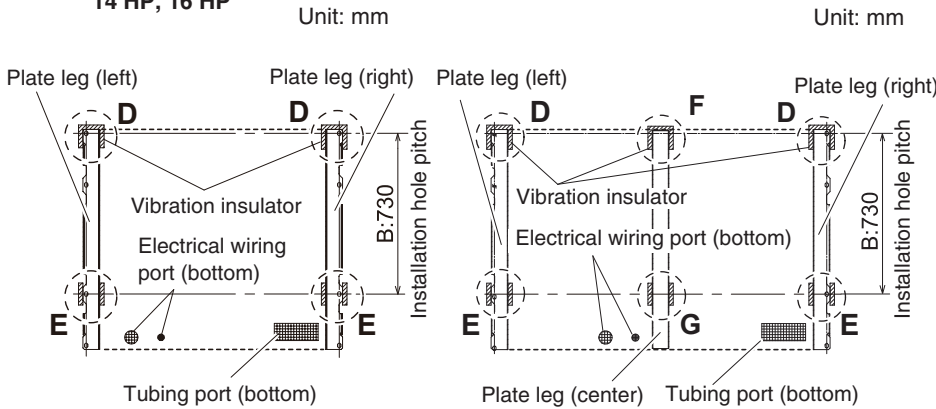

Detailed view of E and G

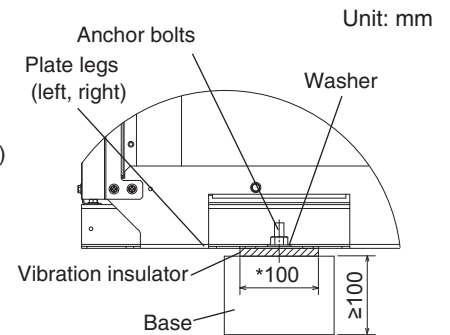

- Below shows vibration insulator position when setting anchor bolt at position C.

Model : 8 HP, 10 HP, 12 HP,
14 HP, 16 HP

Model : 18 HP, 20 HP

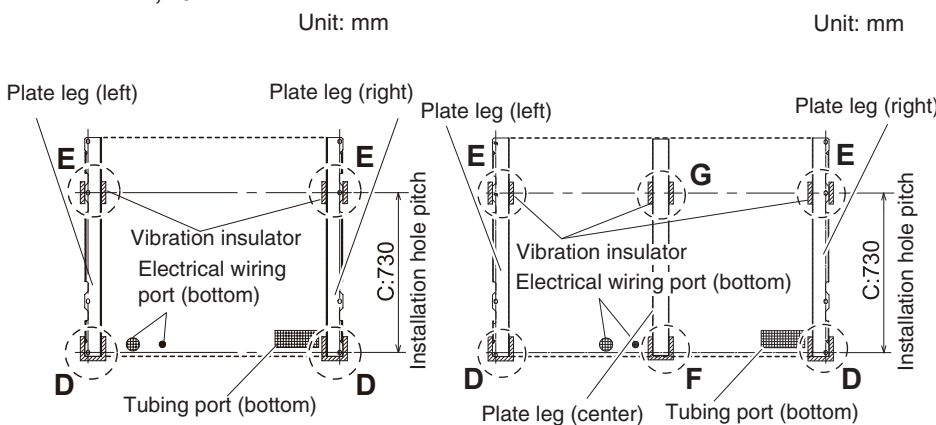

Detailed view of D and F

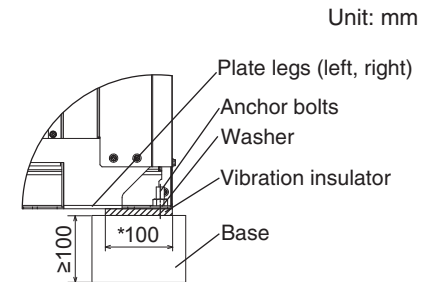

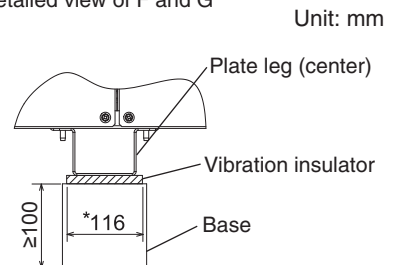

Detailed view of F and G



* Need the vibration insulator under the plate leg at the central location for the installation site.

NOTE: Proceed with the work following the dimensions showing the asterisk.
Anchor bolt and washer are not required at the central plate leg (F and G).

3-3. Routing the Tubing

- The tubing can be routed out either from the front or from the bottom.
 - The connecting valve is contained inside the unit. Therefore, remove the front panel.
- (1) If the tubing is routed out from the front, cut out the slit part ().
 - Be careful not to damage the tubing cover.
 - (2) If the tubing is routed out from the bottom, use cutting pliers or a similar tool to cut out the tubing outlet slit (part indicated by ) from the tubing cover.
 - Be careful not to damage the tubing cover.

Model : 8 HP, 10 HP

Model : 12 HP, 14 HP, 16 HP

Model : 18 HP, 20 HP

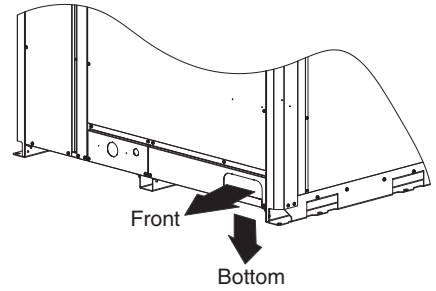
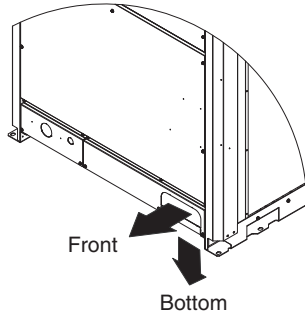
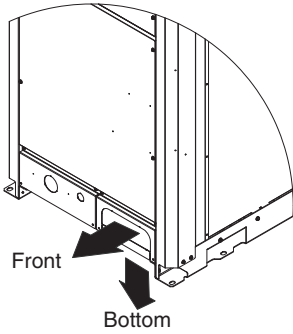

Model : 8 HP, 10 HP

Model : 12 HP, 14 HP, 16 HP

Model : 18 HP, 20 HP

Remove 8 panel screws from front panel.

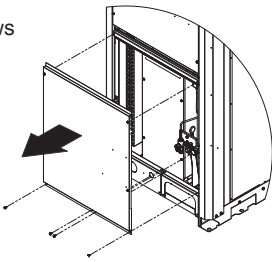

Remove 10 panel screws from front panel.

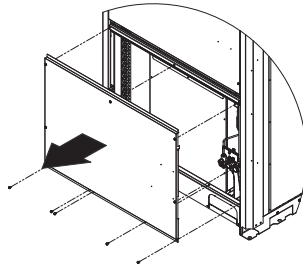

Remove 10 panel screws from front panel.

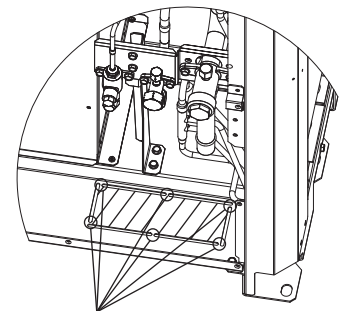
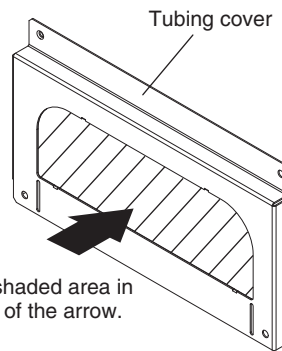
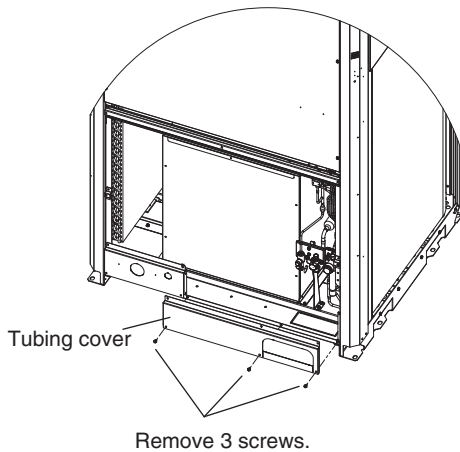
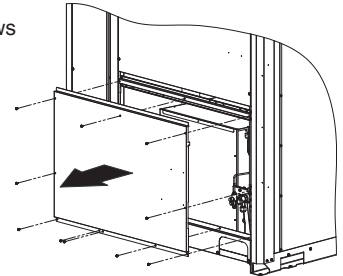

If the tubing is routed out from the bottom, use cutting pliers or a similar tool to cut out the shaded area.

3-4. Prepare the Tubing

- Material: Use seamless phosphorous deoxidized copper tube for refrigeration. Wall thickness shall comply with the applicable legislation. The minimal wall thickness must be in accordance with the table below. For tubes of $\phi 22.22$ or larger, use the material of temper 1/2H or H (Hard copper tube). Do not bend the hard copper tube.
- Tubing size
Use the tubing size indicated in the table below.
- When cutting the tubing, use a tube cutter, and be sure to remove any burrs.
The same applies to distribution tubing (optional).
- When bending the tubes, bend each tube using a radius that is at least 4 times the outer diameter of the tube. When bending, use sufficient care to avoid crushing or damaging the tube.
- For flaring, use a flare tool, and be sure that flaring is performed correctly.



CAUTION

Use sufficient caution during preparation of the tubing.
Seal the tube ends by means of caps or taping to prevent dust, moisture, or other foreign substances from entering the tubes.

Refrigerant tubing

Tubing size (mm)			
Material Temper - O (Soft copper tube)		Material Temper - 1/2 H, H (Hard copper tube)	
Outer dia.	Thickness	Outer dia.	Thickness
$\phi 6.35$	t0.8	$\phi 22.22$	t1.0
$\phi 9.52$	t0.8	$\phi 25.4$	t1.0
$\phi 12.7$	t0.8	$\phi 28.58$	t1.0
$\phi 15.88$	t1.0	$\phi 31.75$	t1.1
$\phi 19.05$	t1.2	$\phi 38.1$	over t1.35
		$\phi 41.28$	over t1.45
		$\phi 44.45$	over t1.55
		$\phi 50.8$	over t1.8

3-5. Connect the Tubing

- When operating the refrigerant tube installation in the field, do not apply the flame of welding to the surrounding sheet-metal parts. If necessary, use a wet rag to prevent overheating of the heat exchanger.

- Except for the 16 HP model, do not use the supplied connector tubing.

Model : 8 HP, 10 HP, 12 HP, 14 HP (Except 16 HP)

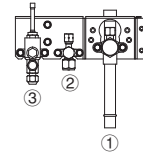

	Refrigerant tubing	Connection method	Supplied parts used?
①	Gas tube	Brazing	No
②	Liquid tube	Flare connection	No
③	Balance tube	Flare connection	No

Model : 16 HP

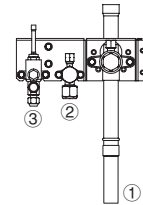

	Refrigerant tubing	Connection method	Supplied parts used?
①	Gas tube	Brazing	yes ($\phi 25.4 \rightarrow \phi 28.58$)
②	Liquid tube	Flare connection	No
③	Balance tube	Flare connection	No

Model : 18 HP, 20 HP

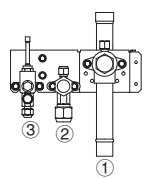

	Refrigerant tubing	Connection method	Supplied parts used?
①	Gas tube	Brazing	No
②	Liquid tube	Flare connection	No
③	Balance tube	Flare connection	No

Refrigerant tube port

- Use caulking, putty, or a similar material to fill any gaps at the refrigerant tube port () in order to prevent rainwater, dust or foreign substances from entering the unit.
* Perform this work even if the tubing is routed out in a downward direction.

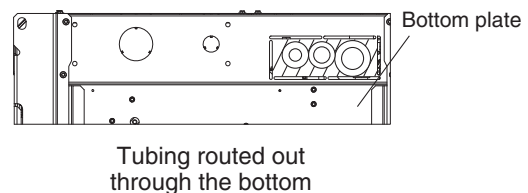
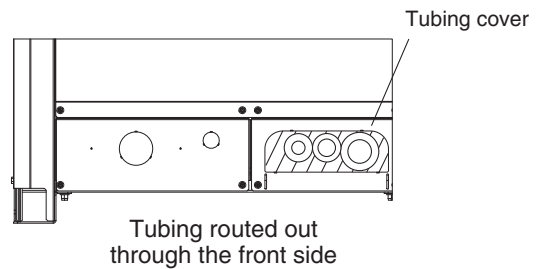

- Tighten each cap as specified below.

Tightening torque for each cap

Cap tightening torque

HP: horsepower

		Unit	8 HP	10 HP	12 HP	14 HP	16 HP	18 HP	20 HP
Liquid tube	Valve cap	N · m	24.5±3.9		53.9±5.9				
		{kgf · cm}	{245±39}		{539±59}				
	Service port cap	N · m	12.7±2						
		{kgf · cm}	{127±20}						
Flare nut	N · m	38±4	55±6		75±7				
	{kgf · cm}	{380±40}	{550±60}		{750±70}				
Gas tube	Valve cap	N · m	42.5±2.5	50±3			72.5±2.5		
		{kgf · cm}	{425±25}	{500±30}			{725±25}		
	Service port cap	N · m	11±1						
		{kgf · cm}	{110±10}						
Balance tube	Valve cap	N · m	22.5±2.5						
		{kgf · cm}	{225±25}						
	Service port cap	N · m	10±1						
		{kgf · cm}	{100±10}						
Flare nut	N · m	16±2							
	{kgf · cm}	{160±20}							

Model : 8 HP

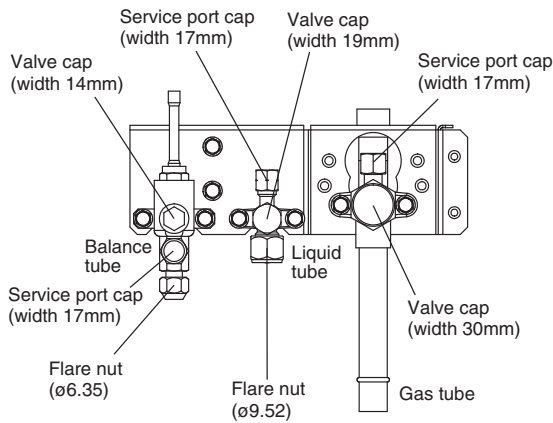

Model: 12 HP, 14 HP, 16 HP

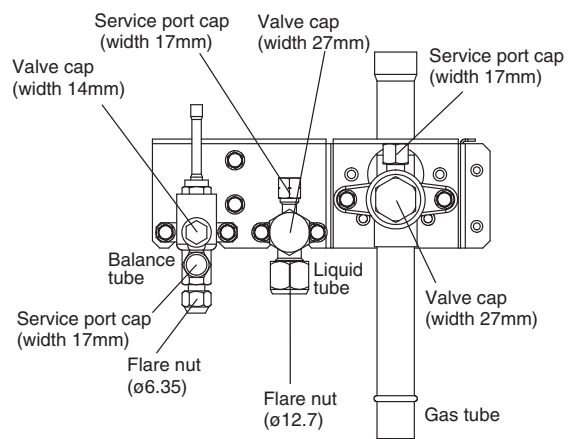

Model: 10 HP

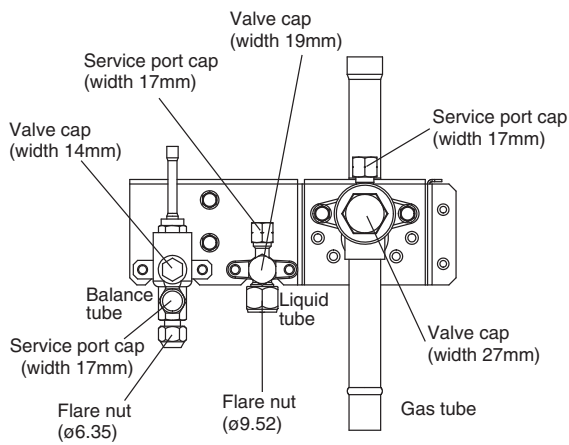

Model: 18 HP, 20 HP

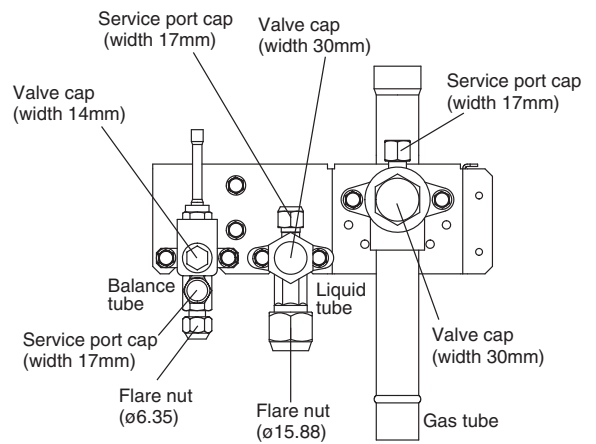

Do not apply an adjustable wrench to the hexagonal part.

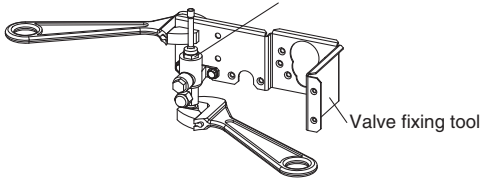

Use two adjustable wrenches when removing or installing the balance tube flare nut.

In particular, do not apply an adjustable wrench to the hexagonal part at the top of the valve.

If force is applied to this part, gas leakage will occur.

Apply an adjustable wrench to settle the fixing tool as shown in the figure. If not used, the valve fixing tool will get distorted.

Use two adjustable wrenches, as shown in the figure, when removing the liquid tube valve flare nut.

1. Do not apply a wrench to the valve cap when removing or installing the flare nuts. Doing so may damage the valve.
2. If the valve cap is left off for a long period of time, refrigerant leakage will occur. Therefore, do not leave the valve cap off.
3. Applying refrigerant oil to the flare surface can be effective in preventing gas leakage, however be sure to use a refrigerant oil which is suitable for the refrigerant that is used in the system.

This unit utilizes R410A refrigerant, and the refrigerant oil is ether oil (synthetic oil). However, hub oil (synthetic oil) can also be used.

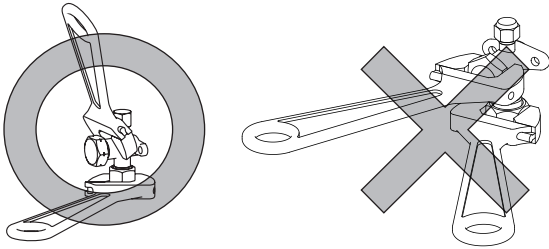

● Precautions for brazing

Be sure to replace the air inside the tube with nitrogen to prevent oxide film from forming during the brazing process.

Be sure to use a damp cloth or other means to cool the valve unit during brazing.

Work method

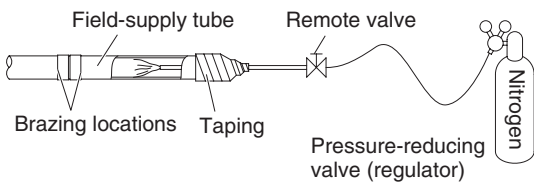

⚠ CAUTION

1. Be sure to use nitrogen
Oxygen, CO₂, and CFC must not be used.
2. Use a pressure-reducing valve on the nitrogen tank.
3. Do not use agents intended to prevent the formation of oxide film. They will adversely affect the refrigeration oil, and may cause equipment failure.
4. The balance tube is not used if only 1 outdoor unit is installed. Use the unit in the same conditions as when it was shipped from the factory.

4. ELECTRICAL WIRING

4-1. General Precautions on Wiring

- (1) Before wiring, confirm the rated voltage of the unit as shown on its nameplate, then carry out the wiring closely following the wiring diagram.
- (2) Provide a power outlet to be used exclusively for each unit, and a power supply disconnect, circuit breaker and earth leakage breaker for overcurrent protection should be provided in the exclusive line.
- (3) To prevent possible hazards from insulation failure, the unit must be grounded.
- (4) Each wiring connection must be done in accordance with the wiring system diagram. Wrong wiring may cause the unit to misoperate or become damaged.
- (5) Do not allow wiring to touch the refrigerant tubing, compressor, or any moving parts of the fan.
- (6) Unauthorized changes in the internal wiring can be very dangerous. The manufacturer will accept no responsibility for any damage or misoperation that occurs as a result of such unauthorized changes.
- (7) Regulations on wire diameters differ from locality to locality. For field wiring rules, please refer to your LOCAL ELECTRICAL CODES before beginning. You must ensure that installation complies with all relevant rules and regulations.
- (8) To prevent malfunction of the air conditioner caused by electrical noise, care must be taken when wiring as follows:
 - The remote control wiring and the inter-unit control wiring should be wired apart from the inter-unit power wiring.
 - Use shielded wires for inter-unit control wiring between units and ground the shield on both sides.
- (9) Use a waterproof conduit for outdoor unit wiring to avoid damaging the wire and to prevent accumulation of liquid inside the unit.

4-2. Wire Length and Wire Diameter for Power Supply System

Outdoor unit

	(A) Power supply		Time delay fuse or circuit capacity	or	(A) Power supply		Time delay fuse or circuit capacity
	Min. wire size	Max. length			Min. wire size	Max. length	
U-8ME2R8(E)	4 mm ² *1	77 m*2	20 A		6 mm ² *1	115 m*2	30 A
U-10ME2R8(E)	4 mm ² *1	54 m*2	25 A		6 mm ² *1	81 m*2	30 A
U-12ME2R8(E)	6 mm ² *1	65 m*2	30 A		—	—	—
U-14ME2R8(E)	10 mm ² *1	84 m*2	35 A		—	—	—
U-16ME2R8(E)	10 mm ² *1	69 m*2	40 A		—	—	—
U-18ME2R8(E)	10 mm ² *1	62 m*2	50 A		16 mm ² *1	100 m*2	50 A
U-20ME2R8(E)	10 mm ² *1	54 m*2	60 A		16 mm ² *1	86 m*2	60 A

Indoor unit

Type	(B) Power supply		Time delay fuse or circuit capacity	Type	(B) Power supply		Time delay fuse or circuit capacity
	Minimum 2 mm ²	2.5 mm ²			Minimum 2 mm ²	2.5 mm ²	
K2	Max. 150 m	—	15 A	M1	—	Max. 130 m	10 – 16 A
Y2	Max. 130 m	—	15 A	P1	—	Max. 130 m	10 – 16 A
K1	—	Max. 150 m	10 – 16 A	R1	—	Max. 130 m	10 – 16 A
U1	—	Max. 130 m	10 – 16 A	E1 (73)	—	Max. 60 m	10 – 16 A
F2	—	Max. 130 m	10 – 16 A	E1 (106)	—	Max. 60 m	10 – 16 A
T2	—	Max. 130 m	10 – 16 A	E1 (140)	—	Max. 60 m	10 – 16 A
D1	—	Max. 130 m	10 – 16 A	E1 (224)	—	Max. 50 m	10 – 16 A
L1	—	Max. 130 m	10 – 16 A	E1 (280)	—	Max. 30 m	10 – 16 A
Z1	—	Max. 130 m	10 – 16 A	E2	—	Max. 30 m	10 – 16 A

Control wiring

(C) Inter-unit (between outdoor and indoor units) control wiring		or	(D) Remote control wiring	
0.75 mm ² Use shielded wiring*3	2.0 mm ² Use shielded wiring*3		0.75 mm ²	
Max. 1,000 m	Max. 2,000 m	Max. 500 m		
(E) Control wiring for group control		(F) Inter-outdoor unit control wiring		
0.75 mm ²	0.75 mm ² Use shielded wiring			
Max. 200 m (Total)	Max. 300 m			

NOTE

*1 Maximum applicable wire for terminal board of outdoor unit : 22 mm²

*2 Maximum length shows a 2% voltage drop.

*3 With ring-type wire terminal

4-3. Wiring System Diagram

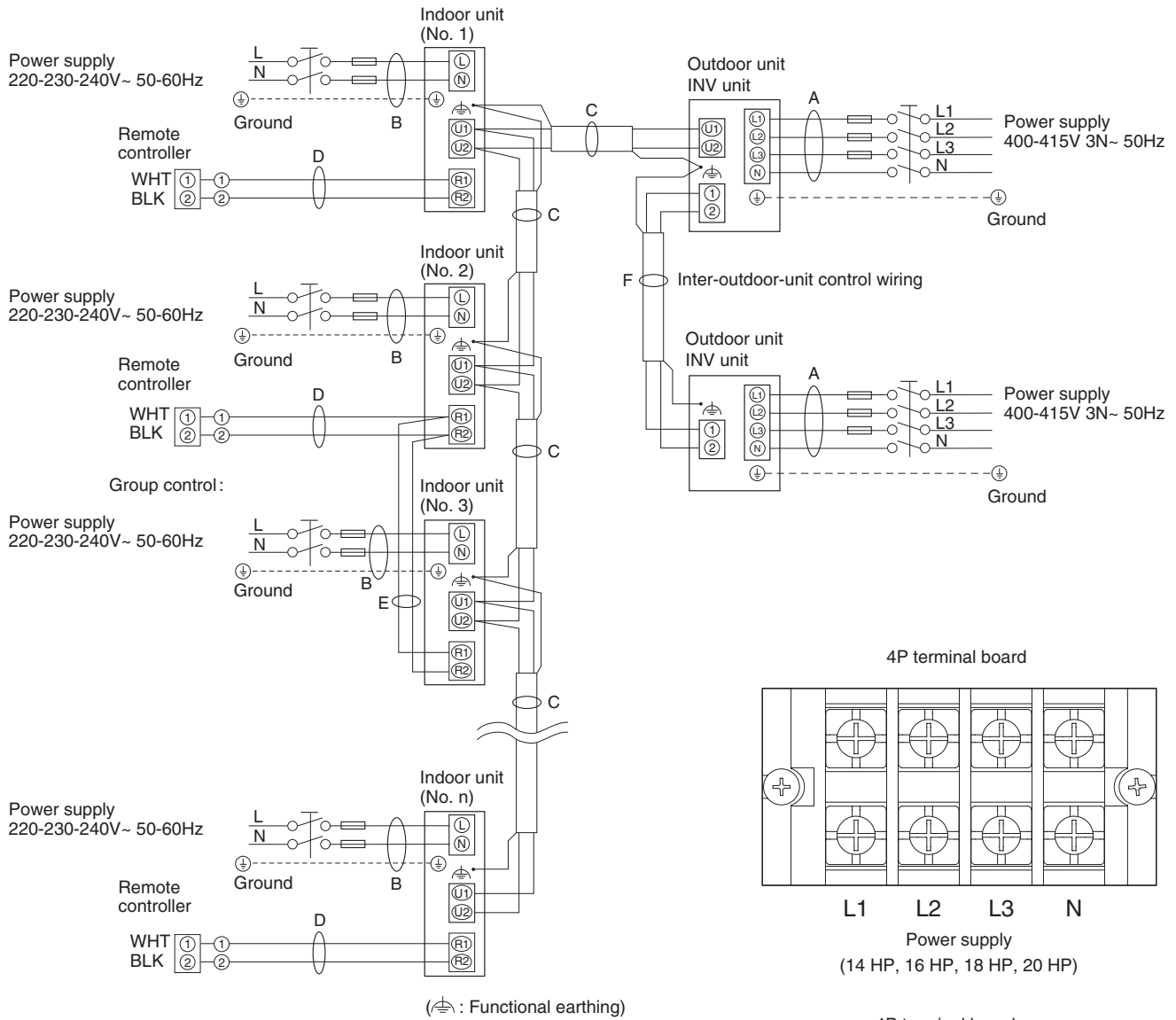

4P terminal board

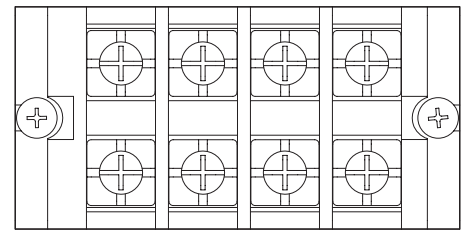

L1 L2 L3 N
Power supply
(14 HP, 16 HP, 18 HP, 20 HP)

4P terminal board

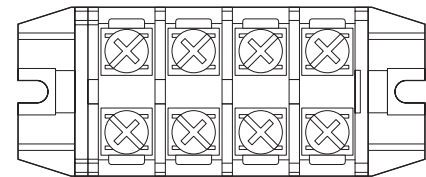

L1 L2 L3 N
Power supply
(8 HP, 10 HP and 12 HP)

4P terminal board

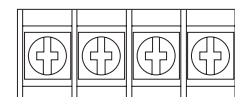

U1 U2 1 2
Inter-unit control wiring Inter-outdoor unit control wiring

Type ME2

NOTE

- (1) See the section "4-2. Wire Length and Wire Diameter for Power Supply System" for the explanation of "A," "B," "C," "D," "E" and "F" in the above diagram.
- (2) The basic connection diagram of the indoor unit shows the 6P terminal board, so the terminal boards in your equipment may differ from the diagram.
- (3) Refrigerant Circuit (R.C.) address should be set before turning the power on.
- (4) Regarding the R.C. address setting, it can be executed by remote controller automatically. See the section "7-4. Auto Address Setting".

CAUTION

- (1) When linking outdoor units in a network, see the section "ATTENTION!".
- (2) Do not install the inter-unit control wiring in a way that forms a loop.

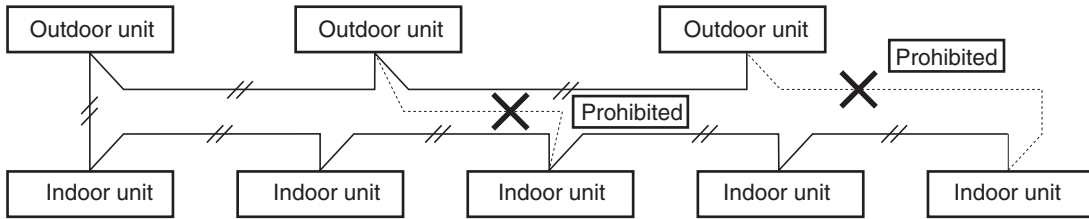

- (3) Do not install the inter-unit control wiring such as star branch wiring. Star branch wiring causes mis-address setting.

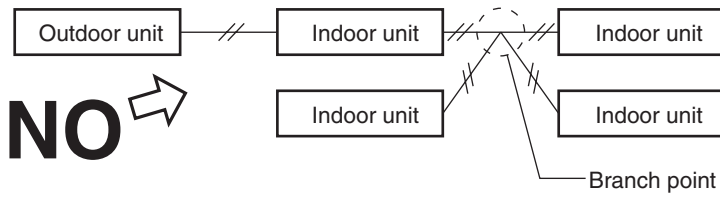

- (4) If branching the inter-unit control wiring, the number of branch points should be 16 or fewer.

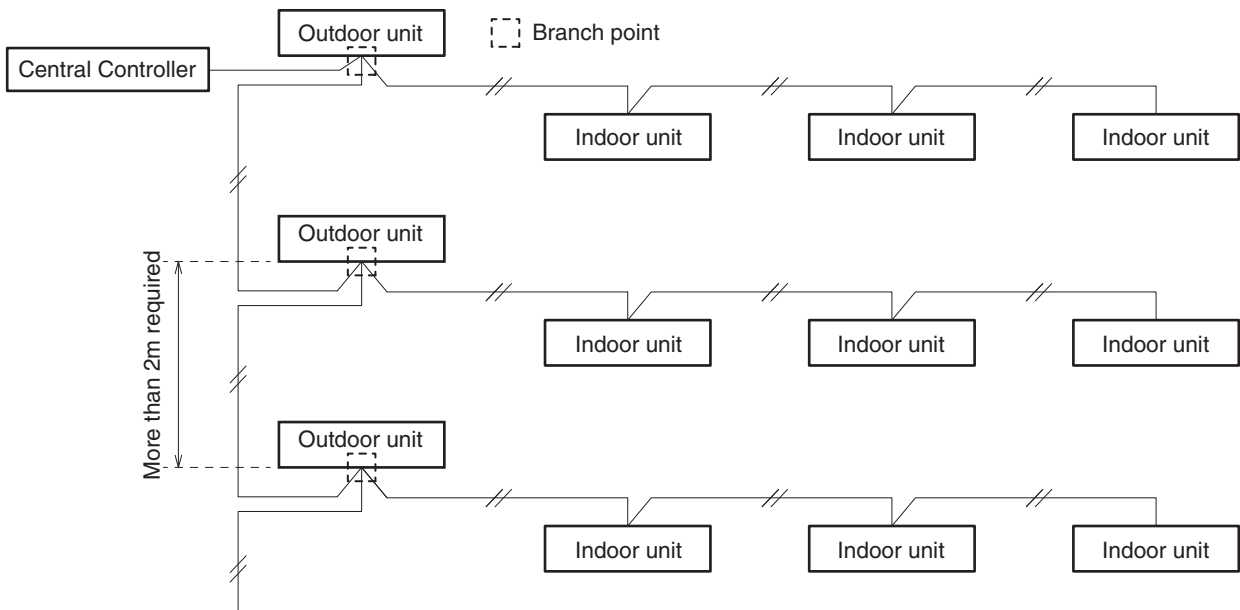

- (5) Use shielded wires for inter-unit control wiring (C) and ground the shield on both sides, otherwise misoperation from noise may occur. Connect wiring as shown in the section “4-3. Wiring System Diagram.”

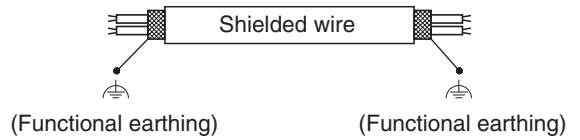

- (6) Use the standard power supply cables for Europe (such as H05RN-F or H07RN-F which conform to CENELEC (HAR) rating specifications) or use the cables based on IEC standard. (60245 IEC57, 60245 IEC66)



WARNING Loose wiring may cause the terminal to overheat or result in unit malfunction. A fire hazard may also exist. Therefore, ensure that all wiring is tightly connected.

When connecting each power wire to the terminal, follow the instructions on “How to Connect Wiring to Terminal” and fasten the wire securely with the fixing screw of the terminal board.

How to Connect Wiring to Terminal

■ For stranded wiring

- (1) Cut the wire end with cutting pliers, then strip the insulation to expose the stranded wiring about 10 mm and tightly twist the wire ends.

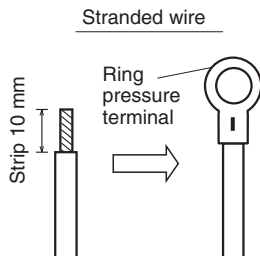

- (2) Using a Phillips head screwdriver, remove the terminal screw(s) on the terminal board.
 (3) Using a ring connector fastener or pliers, securely clamp each stripped wire end with a ring pressure terminal.
 (4) Place the ring pressure terminal, and replace and tighten the removed terminal screw using a screwdriver.

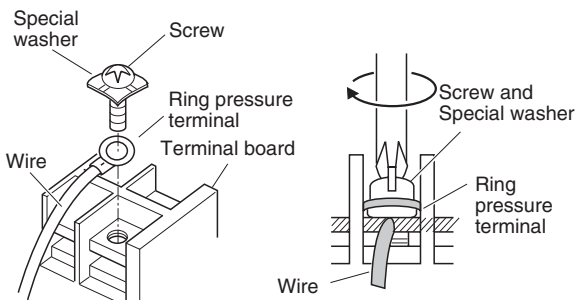

■ Examples of shield wires

- (1) Remove cable coat not to scratch braided shield.



- (2) Unbraid the braided shield carefully and twist the unbraided shield wires tightly together. Insulate the shield wires by covering them with an insulation tube or wrapping insulation tape around them.

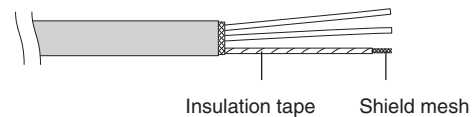

- (3) Remove coat of signal wire.

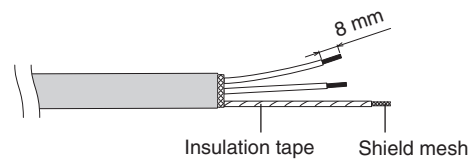

- (4) Attach ring pressure terminals to the signal wires and the shield wires insulated in Step (2).

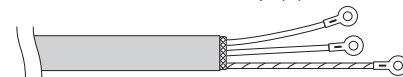

■ Earth wire for power supply

The earth wire should be longer than the other lead wires for electrical safety.

■ Wiring sample

Use this screw when connecting to ground for the inter-unit control wiring.
( : Functional earthing)

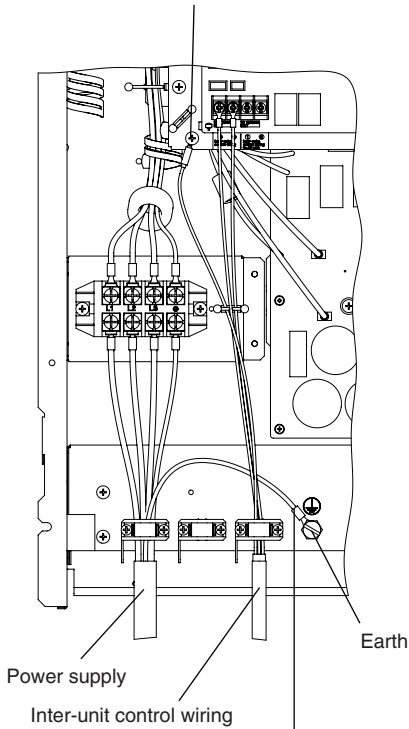

Earth Wiring:
Make the earth wiring
25 - 30 mm longer than
power cable.

Use this screw when connecting to ground for the inter-unit control wiring.
( : Functional earthing)

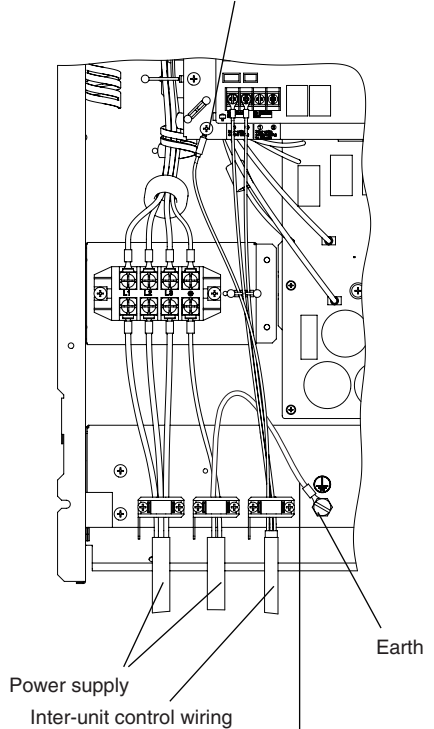

Earth Wiring:
Make the earth wiring
25 - 30 mm longer than
power cable.

Use this screw when connecting to ground for the inter-unit control wiring and inter-outdoor unit control wiring.
( : Functional earthing)

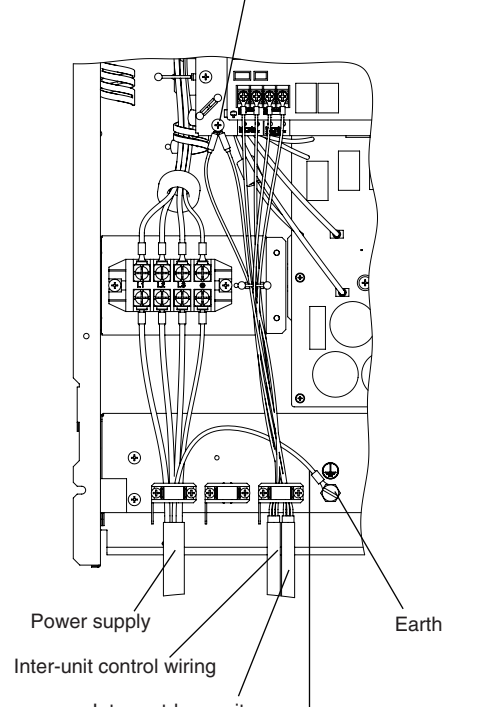

Earth Wiring:
Make the earth wiring
25 - 30 mm longer than
power cable.

Torque values of power supply terminal board

8/10/12 HP: 2.2N·m±0.05N·m {22 kgf·cm ±0.5 kgf·cm}

14/16 HP: 2.7N·m±0.1N·m {27 kgf·cm ±1 kgf·cm}

Torque value of communication terminal board: 1.3N·m±0.1N·m {13 kgf·cm ±1 kgf·cm}

ATTENTION: Comply with the torque values.

If tightening over torque values, the screw will be damaged.

ATTENTION: Apply an adjustable wrench to the valve vertically not to damage the P.C.board.

NOTE

- Fix the wires with the clasper to the wiring fixture plates (2 locations) and do not allow them to touch the refrigerant tubing and compressor.
- Use a waterproof conduit for outdoor unit wiring to avoid damaging the wire and to prevent accumulation of liquid inside the unit.

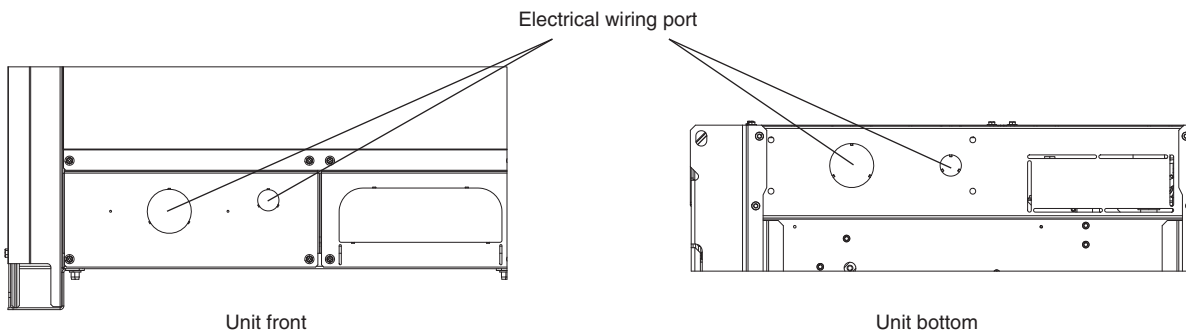

Connection for demand and forced stop

■ Connection procedures

Be sure to always turn the power off before setting up the wire and cable connections.
Failure to do so may lead to electric shocks or malfunctions.

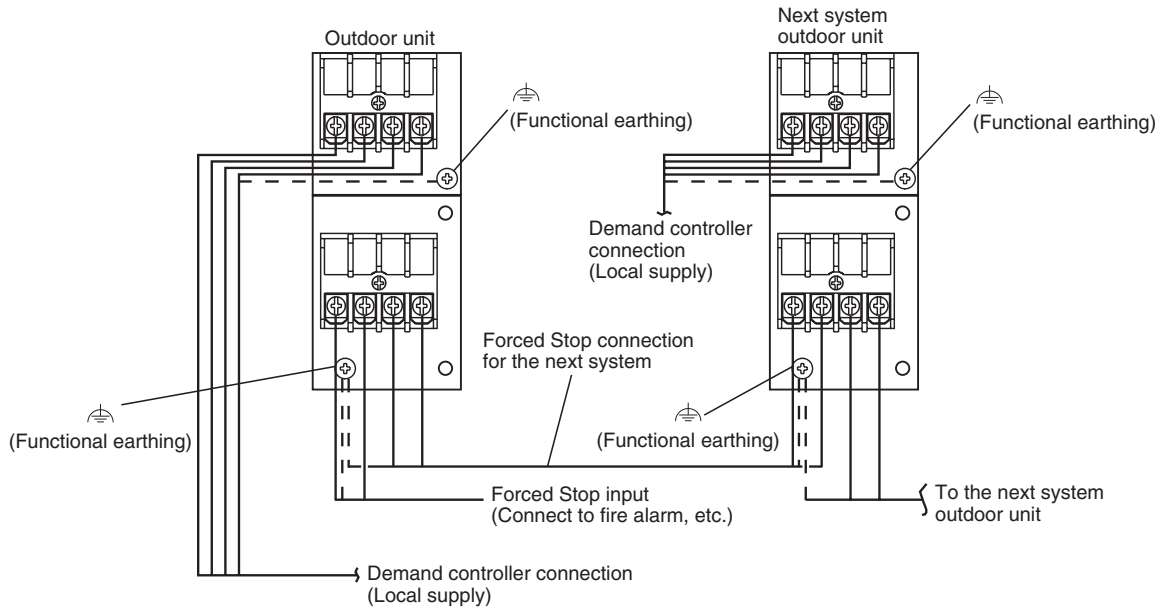

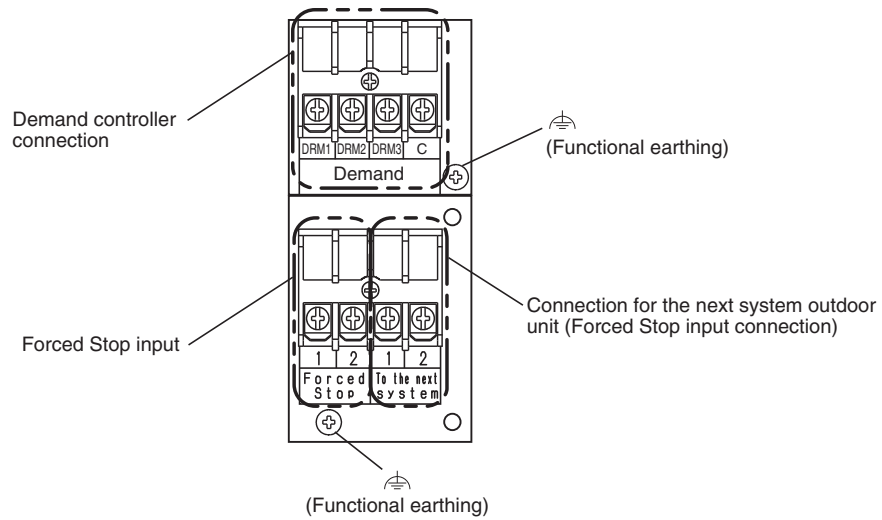

The demand terminal setup is shown in the following illustration.

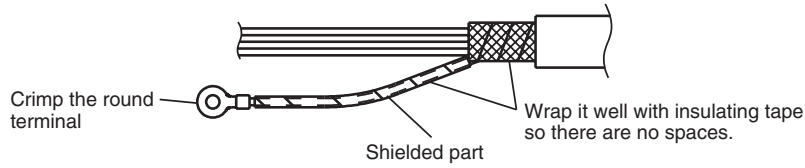

- Use a shielded cable for the cable connection.

Twist out the end of the shielded part of the cable, crimp it with a round terminal, and connect it to ⚡ (Functional earthing) screw. After crimping it with a round terminal, wrap it with insulating tape so there are no spaces and adjust it so the shielded part does not come into contact with any live parts.



 CAUTION	<p>Be sure that the shielded part of the cable does not come into contact with the terminal block or any live parts. Failure to do so may lead to electric shock or fire.</p>
--	---

When connected to the forced stop input

With the Forced Stop input, it is possible to override air conditioning operations to force a stop when signals are received from fire alarms, etc.

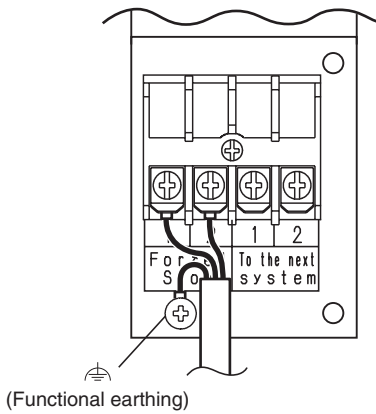

Connect the wire (2-wire) to points 1 and 2 on the left side of the terminal block.

The shielded part of the cable is connected with ⚡ (Functional earthing) at the bottom of the terminal block.

Secure the wire with the cord clamp located on the lower part of the terminal block.

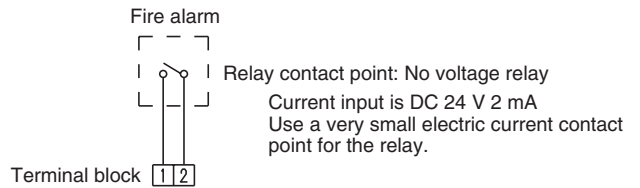

When connecting the demand controller input

It is possible to choose various demand levels. Refer to the table shown on the right.

Terminal No. for demand section	Description
DRM3	Approx. 75% of rated power input
DRM2	Approx. 50% of rated power input
DRM1	Compressor off

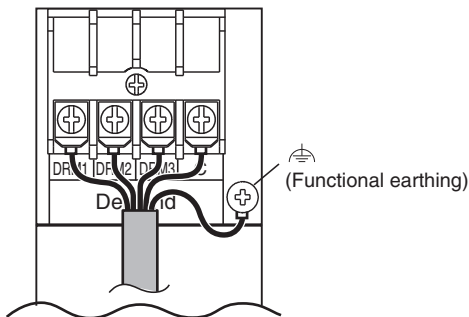

Connect the wire (4-wire) to the Demand section (DRM1, DRM2, DRM3, C) on the terminal block.

The shielded part of the cable is connected with ⚡ (Functional earthing) at the bottom of the terminal block.

Secure the wire with the cord clamp located on the lower part of the terminal block.

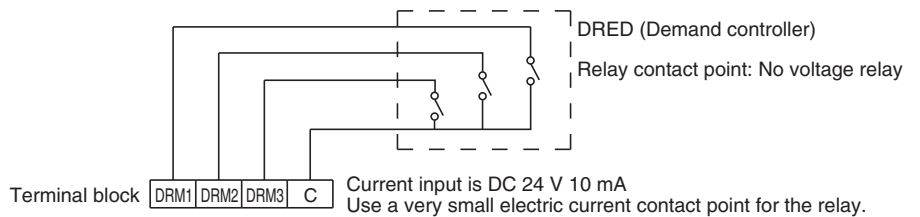

When connecting to the next system unit

- Forced Stop input can be transferred to the next system unit.
- When using the Forced Stop input, connect the wiring to terminal points 1 and 2 on the right side of the lower part of the terminal block.
- The maximum wire/cable length is 100 m.
- The demand control cannot be transferred to the next system unit.
- When transferring to the next system, the maximum number of connected units is 30.

1. Connecting the wiring to the lower part of the terminal block.

When transferring the Forced Stop input to the next system, connect the wire (2-wire) to terminal points 1 and 2 at the lower right side of the terminal block.

The shielded part of the shielded cable is connected with  (Functional earthing) at the bottom of the terminal block. Secure the wire with the cord clamp located on the lower part of the terminal block.

2. Connecting the shielded cable to the terminal block for the next system.

For the Forced Stop input, connect the wire to terminal points 1 and 2 at the lower right side of the terminal block.

When connecting to the next system, be sure to connect to the appropriate terminal point due to the polarity.

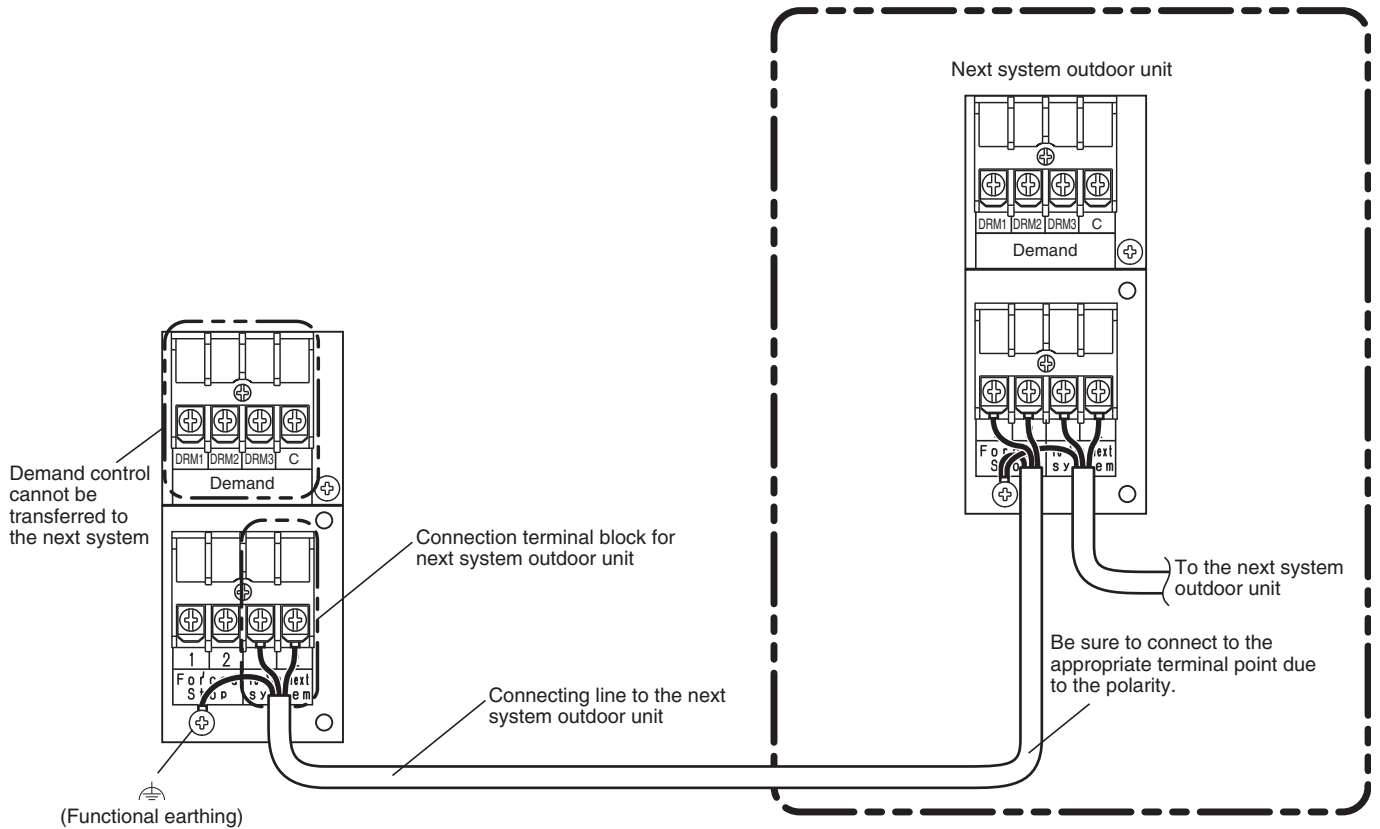

■ Wiring procedures

Follow the wiring procedure below for terminal connections.

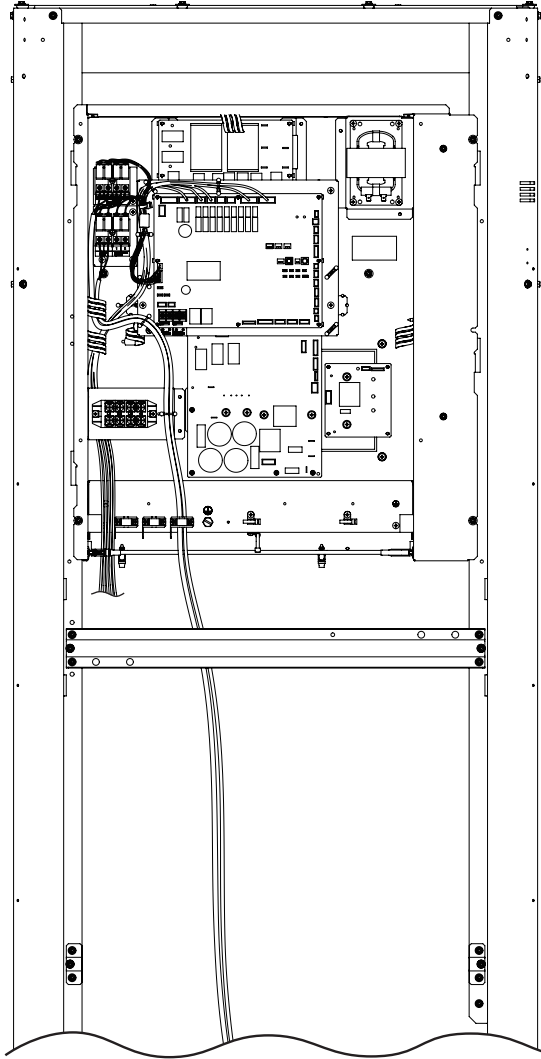

- (1) Remove the wire clamps from the outdoor unit.

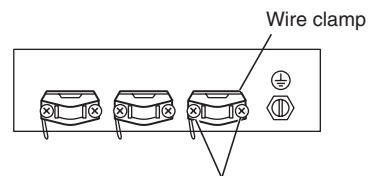

Loosen two screws to remove.

- (2) Secure the wires and cables with the wire clamps.
- (3) Install the wire clamps on the outdoor unit.

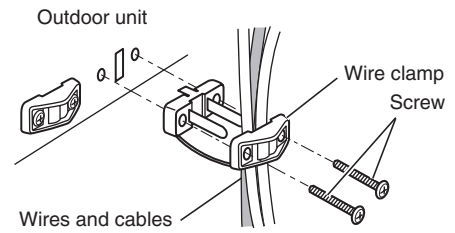

■ Check after completing installation

Check the signals to make sure the unit operates properly with the use of an external input device.

5. HOW TO PROCESS TUBING

The liquid tubing side is connected by a flare nut, and the gas tubing side is connected by brazing.

5-1. Connecting the Refrigerant Tubing

Use of the Flaring Method

Many of conventional split system air conditioners employ the flaring method to connect refrigerant tubes which run between indoor and outdoor units. In this method, the copper tubes are flared at each end and connected with flare nuts.

Flaring Procedure with a Flare Tool

- (1) Cut the copper tube to the required length with a tube cutter. It is recommended to cut approx. 30 – 50 cm longer than the tubing length you estimate.
- (2) Remove burrs at the end of the copper tube with a tube reamer or a similar tool. This process is important and should be done carefully to make a good flare. Be sure to keep any contaminants (moisture, dirt, metal filings, etc.) from entering the tubing.

Deburring

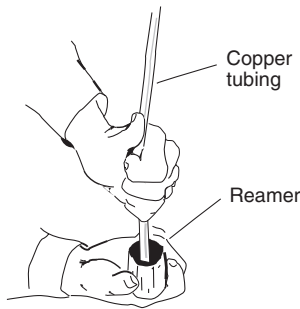
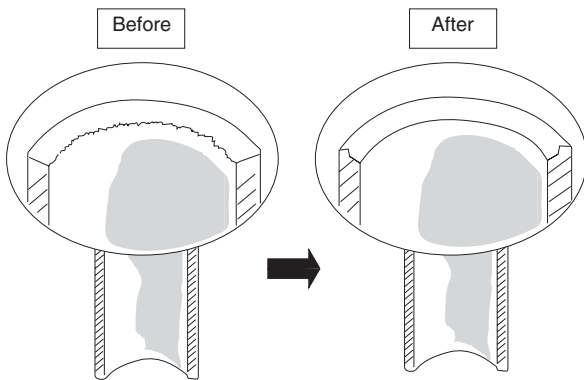

NOTE

When reaming, hold the tube end downward and be sure that no copper scraps fall into the tube.

- (3) Remove the flare nut from the unit and be sure to mount it on the copper tube.
- (4) Make a flare at the end of copper tube with a flare tool.

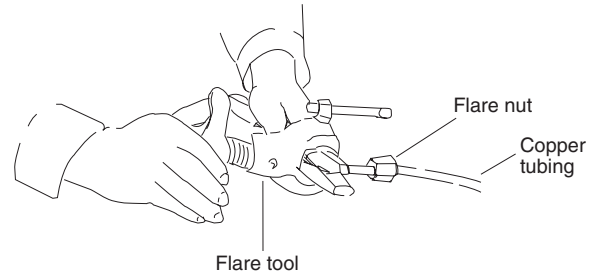

NOTE

A good flare should have the following characteristics:

- Inside surface is glossy and smooth
- Edge is smooth
- Tapered sides are of uniform length

Caution Before Connecting Tubes Tightly

- (1) Apply a sealing cap or water-proof tape to prevent dust or water from entering the tubes before they are used.
- (2) Be sure to apply refrigerant lubricant (ether oil) to the inside of the flare nut before making piping connections. This is effective for reducing gas leaks.

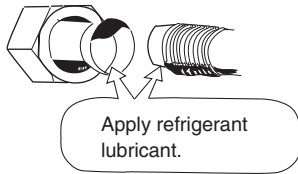

- (3) For proper connection, align the union tube and flare tube straight with each other, then screw in the flare nut lightly at first to obtain a smooth match.

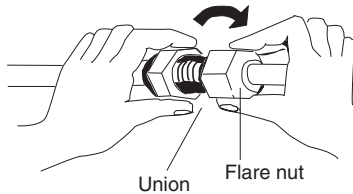

- Adjust the shape of the liquid tube using a tube bender at the installation site and connect it to the liquid tubing side valve using a flare.

Cautions During Brazing

- **Replace air inside the tube with nitrogen gas to prevent copper oxide film from forming during the brazing process. (Oxygen, carbon dioxide and Freon are not acceptable.)**
- **Do not allow the tubing to get too hot during brazing. The nitrogen gas inside the tubing may overheat, causing refrigerant system valves to become damaged. Therefore allow the tubing to cool when brazing.**
- **Use a reducing valve for the nitrogen cylinder.**
- **Do not use agents intended to prevent the formation of oxide film. These agents adversely affect the refrigerant and refrigerant oil, and may cause damage or malfunctions.**

5-2. Connecting Tubing Between Indoor and Outdoor Units

- (1) Tightly connect the indoor-side refrigerant tubing extended from the wall with the outdoor-side tubing.
- (2) To fasten the flare nuts, apply the following specified torque:
 - When removing the flare nuts from the tubing connections, or when tightening them after connecting the tubing, be sure to use a torque wrench and a spanner.

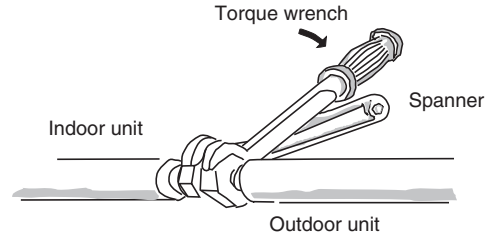

If the flare nuts are over-tightened, the flare may be damaged, which could result refrigerant leakage and cause injury or asphyxiation to room occupants.

- For the flare nuts at tubing connections, be sure to use the flare nuts that were supplied with the unit, or else flare nuts for R410A (type 2). The refrigerant tubing that is used must be of the correct wall thickness as shown in the following table.

Tube diameter	Tightening torque, approximate	Tube thickness
ø6.35 (1/4")	16±2 N · m {160±20 kgf · cm}	0.8 mm
ø9.52 (3/8")	38±4 N · m {380±40 kgf · cm}	0.8 mm
ø12.7 (1/2")	55±6 N · m {550±60 kgf · cm}	0.8 mm
ø15.88 (5/8")	75±7 N · m {750±70 kgf · cm}	1.0 mm
ø19.05 (3/4")	110±10 N · m {1100±100 kgf · cm}	1.2 mm

Because the pressure is approximately 1.6 times higher than conventional refrigerant pressure, the use of ordinary flare nuts (type 1) or thin-walled tubes may result in tube rupture, injury, or asphyxiation caused by refrigerant leakage.

- In order to prevent damage to the flare caused by over-tightening of the flare nuts, use the table above as a guide when tightening.
- When tightening the flare nut on the liquid tube, use an adjustable wrench with a nominal handle length of 200 mm.

5-3. Insulating the Refrigerant Tubing

Tubing Insulation

● Standard Selection of Insulation Material

Under the environment of the high temperature and high humidity, the surface of the insulation material is easy to become condensation. This will result in leakage and dew drop. Refer to the chart shown below when selecting the insulation material. In case that the ambient temperature and relative humidity are placed above the line of the insulation thickness, the condensation may occasionally make a dew drop on the surface of the insulation material. In this case, select the better insulation efficiency.

* However, since the condition will be different due to the sort of the insulator material and the environmental condition of the installation place, see the chart shown below as a reference when making a selection.

Standard Selection of Tubing Insulation

Sort of insulation material	Polyethylene heat resisting material
Upper limits of usage temperature	Gas tubing : 120 °C or above Other tubing : 80 °C or above
Calculating condition	
Thermal conductivity of insulation material	0.043 W/(m · K) (Average temperature 23 °C)
Refrigerant temperature	2 °C

Two tubes arranged together

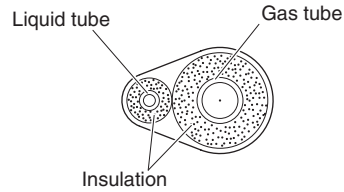

Three tubes arranged together

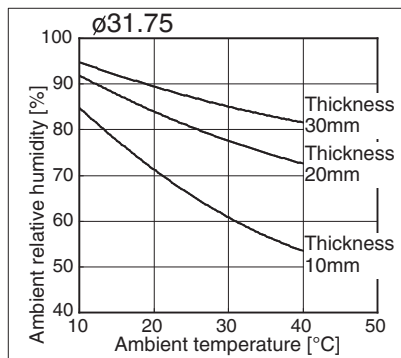
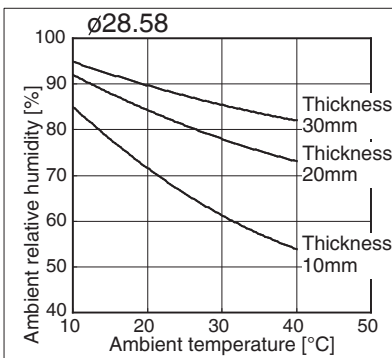
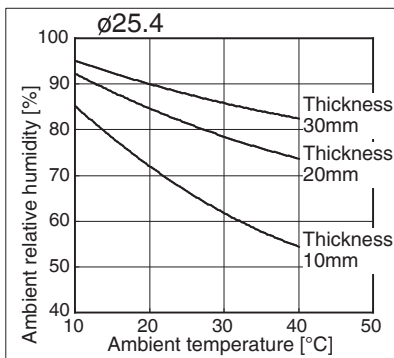
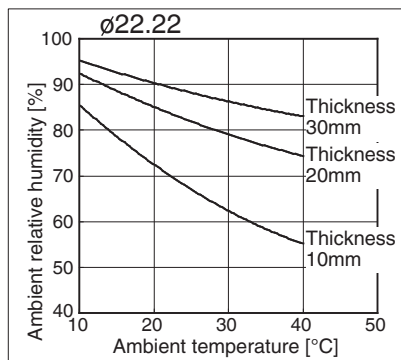
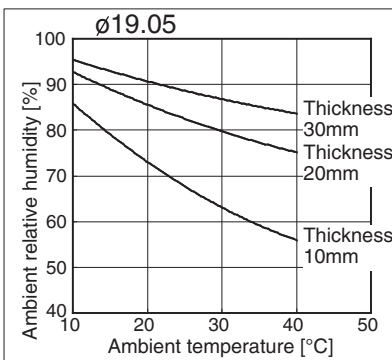
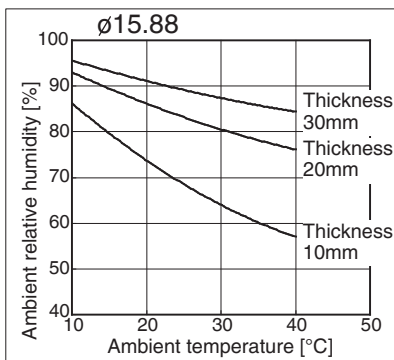
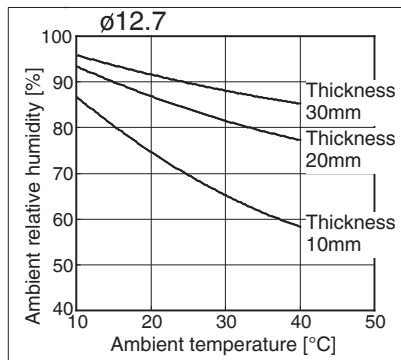
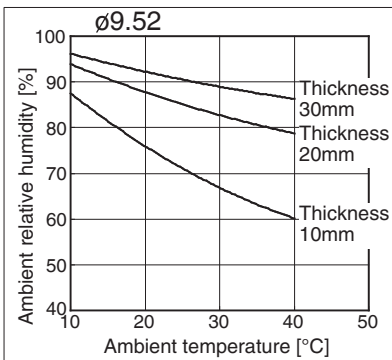
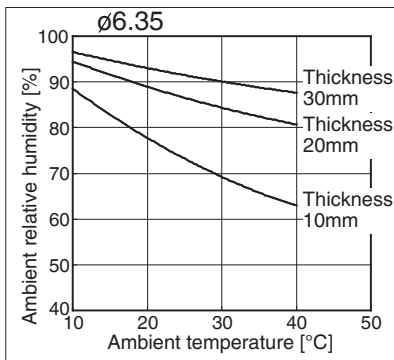
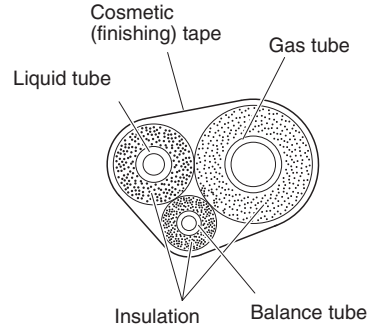

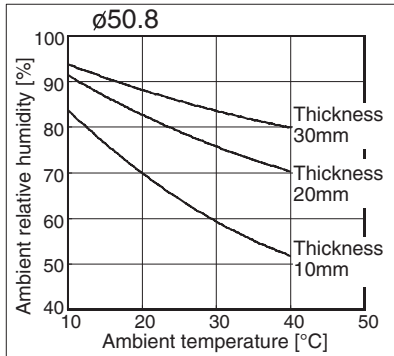
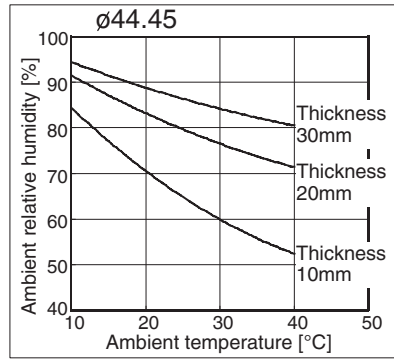
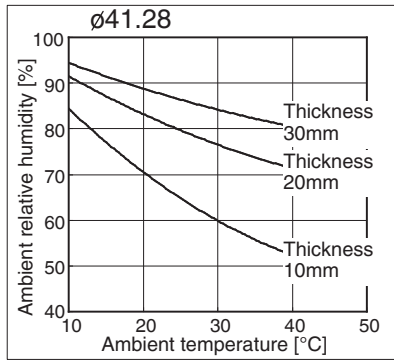
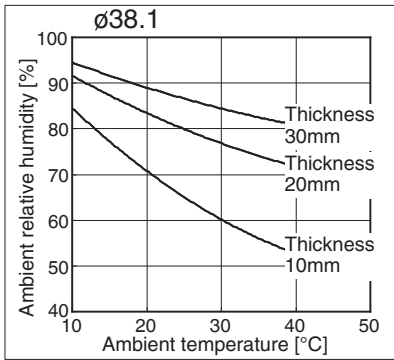

CAUTION

If the exterior of the outdoor unit valves has been finished with a square duct covering, make sure you allow sufficient space to use the valves and to allow the panels to be attached and removed.

Taping the flare nuts

Wind the white insulation tape around the flare nuts at the gas tube connections. Then cover up the tubing connections with the flare insulator, and fill the gap at the union with the supplied black insulation tape. Finally, fasten the insulator at both ends with the supplied vinyl clamps.

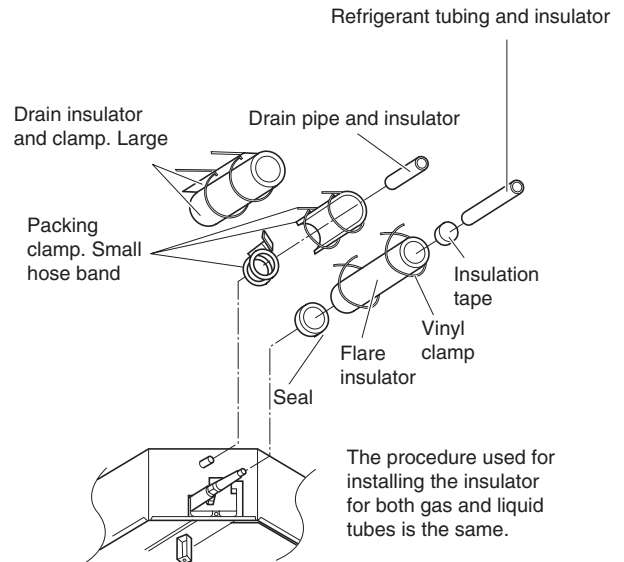
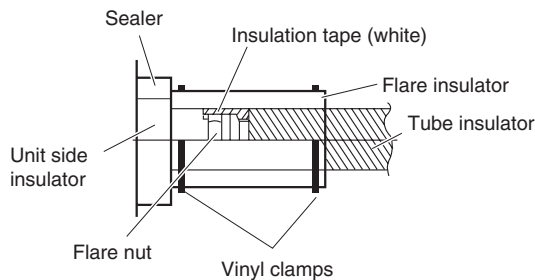

Never grasp the drain or refrigerant connecting outlets when moving the unit.

Insulation material

The material used for insulation must have good insulation characteristics, be easy to use, be age resistant, and must not easily absorb moisture.

Be sure to use the heat-resistant insulator corresponding to the gas tube of 120 °C or above and other tubes of 80 °C or above.



CAUTION

After a tube has been insulated, never try to bend it into a narrow curve because it can cause the tube to break or crack.

5-4. Taping the Tubes

- (1) At this time, the refrigerant tubes (and electrical wiring if local codes permit) should be taped together with armoring tape in 1 bundle. To prevent the condensation from overflowing the drain pan, keep the drain hose separate from the refrigerant tubing.
- (2) Wrap the armoring tape from the bottom of the outdoor unit to the top of the tubing where it enters the wall. As you wrap the tubing, overlap half of each previous tape turn.
- (3) Clamp the tubing bundle to the wall, using 1 clamp approx. each meter.

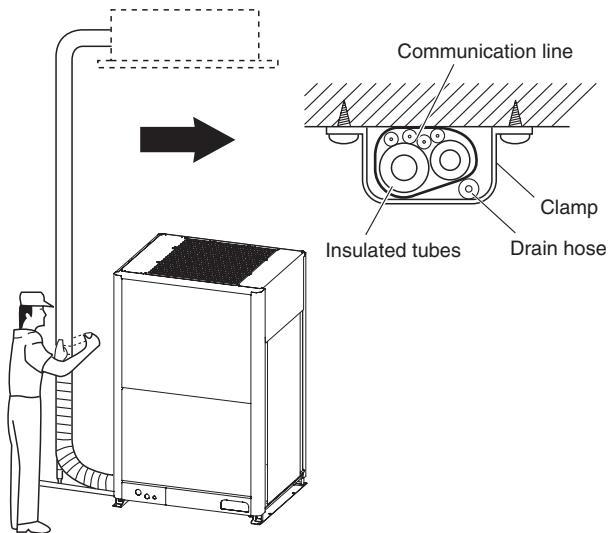

NOTE

Do not wind the armoring tape too tightly since this will decrease the heat insulation effect. Also ensure that the condensation drain hose splits away from the bundle and drips clear of the unit and the tubing.

5-5. Finishing the Installation

After finishing insulating and taping over the tubing, use sealing putty to seal off the hole in the wall to prevent rain and draft from entering.

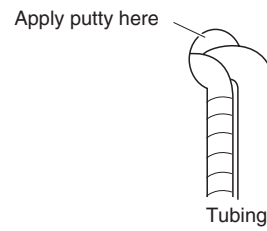

6. AIR PURGING

Leak Test and Evacuation

Do a leak test by performing the following procedures. Confirm that there is no leakage in the connection area.

- Connect the nitrogen gas cylinder, refrigerant cylinder and vacuum pump to the service ports of the gas tube, liquid tube and balance tube as shown in figure. Be sure to keep the valves of gas tube, liquid tube and balance tube closed.

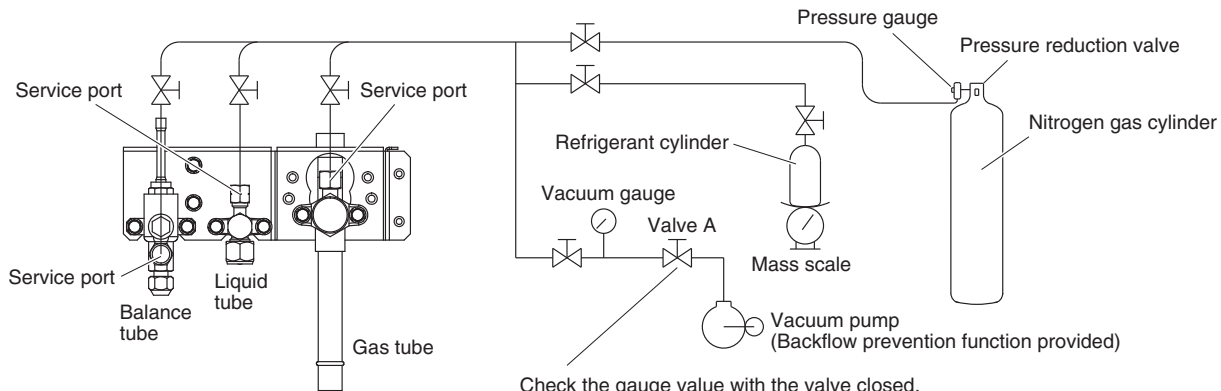

Check the gauge value with the valve closed.
Confirm the vacuum gauge is below -0.1 Mpa (absolute pressure 0.6 kPa (5 Torr)).

Leak Tightness Test Method :

The design pressure and the pressure of the leak test of this unit is 3.8 MPa.

- Do not pressurize to the default value at once. Pressurize gradually.
 - (1) Pressurize to 0.5 MPa and then leave it for 5 minutes to ensure that the pressure does not drop.
 - (2) Pressurize to 1.5 MPa and then leave it for 5 minutes to ensure that the pressure does not drop.
 - (3) For the test, pressurize to 3.8 MPa and leave it for about 1 day to ensure that the pressure does not drop.
 - (4) The pressure drops at a rate of approximately 0.01 MPa per 1°C decrease in ambient temperature. Therefore, make a pressure correction. The equation for the pressure correction is given below.

$$\text{Measured absolute pressure} = \frac{(\text{Pressurized absolute pressure}) \times (\text{Measured temperature} + 273)}{(\text{Pressurized temperature} + 273)}$$

- (5) In case that the pressure drop is observed, there is a possibility of leakage. Make a correction and perform the leak test again.

Evacuation Method :

- After performing the leak test, evacuate and perform vacuum drying the indoor unit and tubing.
 - (1) Confirm that the shut-off valves of gas tube, liquid tube and balance tube are kept closed.
 - (2) Connect the vacuum pump and vacuum gauge to the service ports of the gas tube, liquid tube and balance tube as shown in figure.
 - (3) Evacuate and perform vacuum drying the indoor unit and tubing.
 - (4) Evacuate until the reading of the vacuum gauge reaches less than -0.1 MPa (absolute pressure 0.6 kPa (5 Torr)) or lower.
 - (5) When the gauge reading is less than -0.1 MPa, run the vacuum pump for over one hour continuously and then evacuate and perform vacuum drying.
 - (6) Fully close the valve A. Then loosen the hose connected to the vacuum pump and turn off the vacuum pump.
 - (7) After leaving it for one hour, confirm the pressure of the vacuum gauge does not increase shortly after Step (6) above. Then stop vacuum drying.

In case that the pressure of the vacuum gauge is increased, water might be left inside of the tube or leaked. If any water remains inside the tube, fill with the dry nitrogen (0.05 MPa (gauge pressure)) until the positive pressure is reached. Then evacuate and perform vacuum drying again. (Due to prevention of humid air entering the pipe before returning to positive pressure.)

If there is any water leakage, eliminate leaks and perform the leak test again, and then evacuate and perform vacuum drying again.

NOTE

Be sure to perform the operations from all service ports simultaneously.

It is recommended that the leak test for the tubing among the first unit be checked without connecting to the outdoor unit: tube alone.

Use nitrogen gas for the leak tightness test. (Oxygen, carbon dioxide gas and freon gas shall be prohibited.)

- Be sure to use vacuum gauge. Gauge manifold cannot read precisely.
- Use the vacuum pump with the backflow prevention function. If not, there is a risk that the oil filled in the vacuum pump will flow back when the vacuum pump is stopped.



CAUTION Use a cylinder designed for use with R410A respectively.

Charging additional refrigerant

- Charging additional refrigerant (calculated from the liquid tube length as shown in the section “1-8. Additional Refrigerant Charge”) using the liquid tube service valve.
- Use a balance to measure the refrigerant accurately.
- If the additional refrigerant charge amount cannot be charged at once, charge the remaining refrigerant in liquid form by using the refrigerant charge connection port with the system in cooling operation mode at the time of test run.

Finishing the job

- (1) With a hex wrench, turn the liquid tube service valve stem counter-clockwise to fully open the valve.
- (2) Turn the gas tube service valve stem counter-clockwise to fully open the valve.



CAUTION To avoid gas from leaking when removing the charge hose, make sure the stem of the gas tube is turned all the way out (“BACK SEAT” position).

- (3) Loosen the charge hose connected to the gas tube service port (1/4 in.) slightly to release the pressure, then remove the hose.
- (4) Replace the 1/4 in. flare nut and its bonnet on the gas tube service port and fasten the flare nut securely with an adjustable wrench or box wrench. This process is very important to prevent gas from leaking from the system.
- (5) Replace the valve caps at both gas and liquid service valves and fasten them securely.

This completes air purging with a vacuum pump. The air conditioner is now ready for a test run.

7. TEST RUN

7-1. Preparing for Test Run

● Before attempting to start the air conditioner, check the following.

- (1) All loose matter is removed from the cabinet especially steel filings, bits of wire, and clips.
- (2) The control wiring is correctly connected and all electrical connections are tight.
- (3) The protective spacers for the compressor used for transportation have been removed. If not, remove them now.
- (4) The transportation pads for the indoor fan have been removed. If not, remove them now.
- (5) The power has been connected to the unit for at least 5 hours before starting the compressor. The bottom of the compressor should be warm to the touch and the crankcase heater around the feet of the compressor should be hot to the touch.

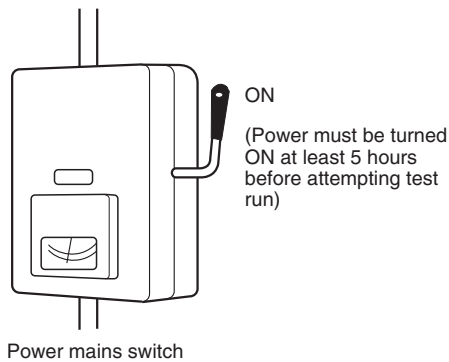

- (6) Both the gas and liquid tube service valves are open. If not, open them now.

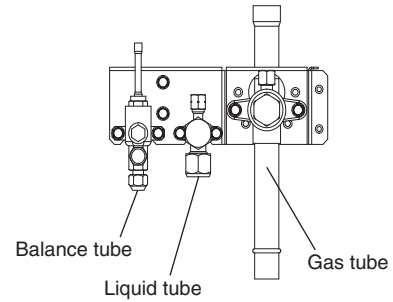

- (7) Do not perform the heating test run out of range temperatures using in heating mode.
- (8) Request that the customer be present for the trial run. Explain the contents of the operating instructions, then have the customer actually operate the system.
- (9) Be sure to give the operating instructions and installation instructions to the customer.
- (10) When replacing the control PCB, be sure to make all the same settings on the new PCB as were in use before replacement.
The existing EEPROM is not changed, and is connected to the new control PCB.

7-2. Test Run Procedure

Notes:



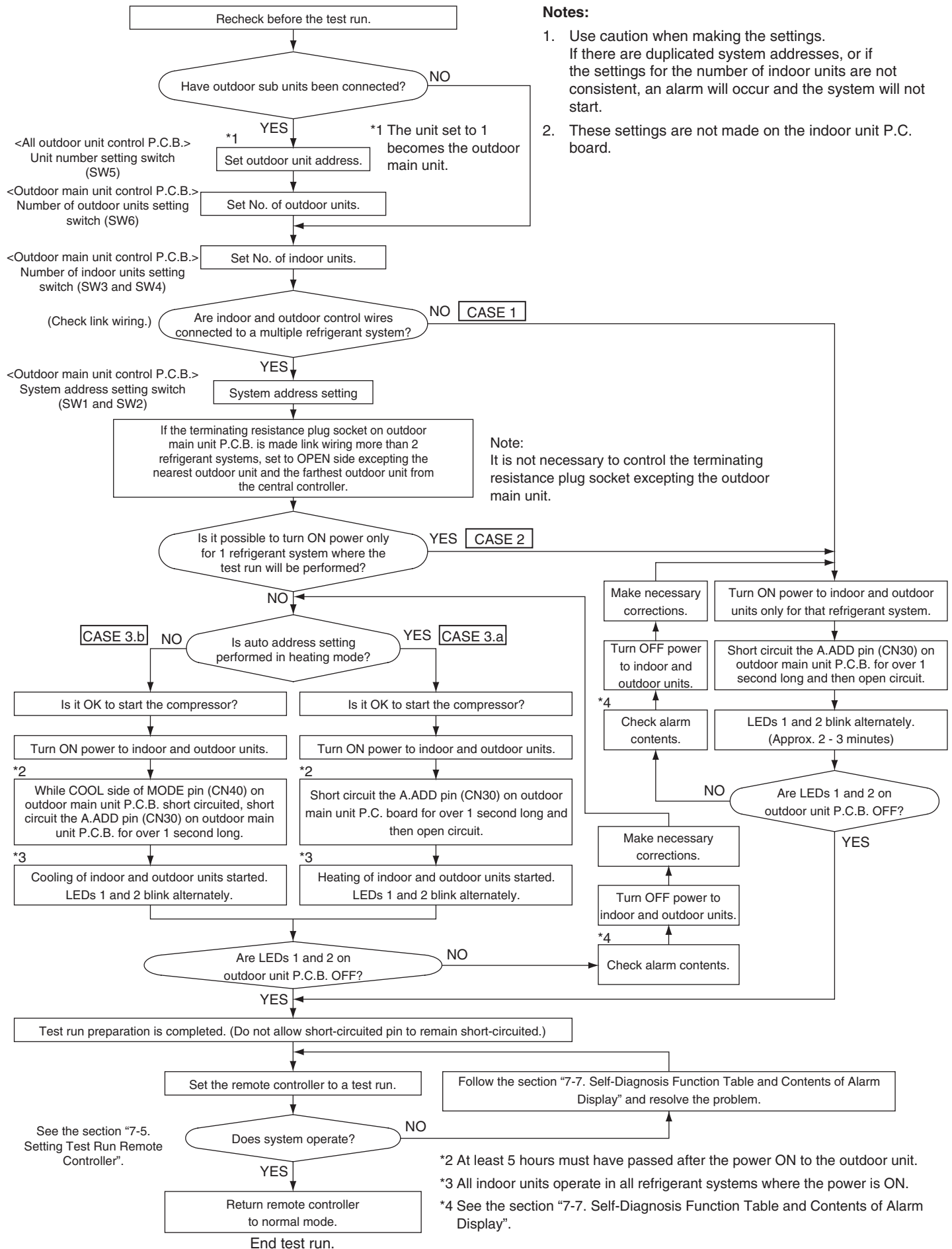



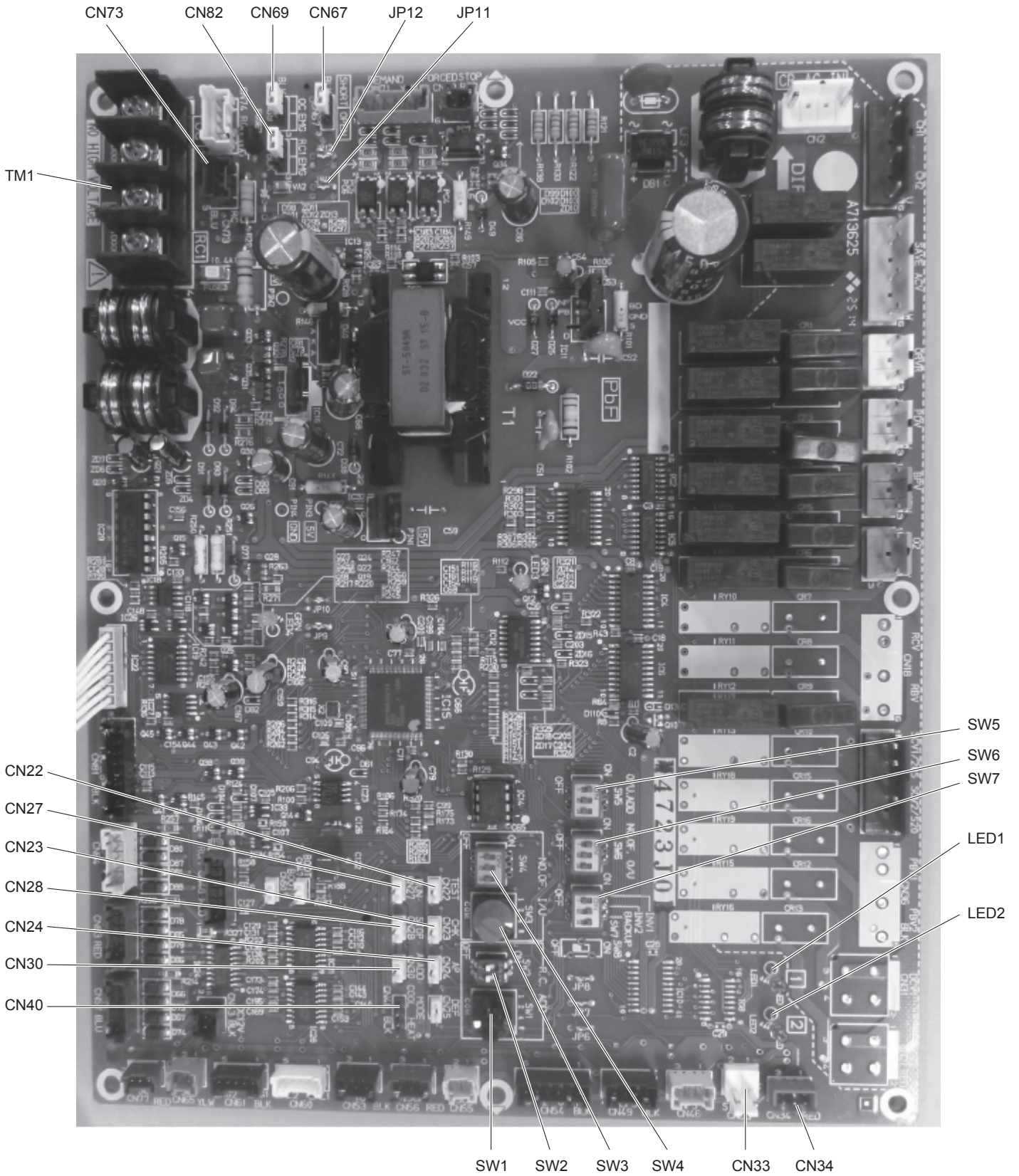







1. Use caution when making the settings.
If there are duplicated system addresses, or if the settings for the number of indoor units are not consistent, an alarm will occur and the system will not start.
2. These settings are not made on the indoor unit P.C. board.











7-3. Main Outdoor Unit PCB Setting



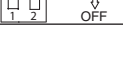

● Examples of the No. of indoor units settings (SW4, SW3)

No. of indoor units	Indoor unit setting (SW4) (3P DIP switch) 10 20 30	Indoor unit setting (SW3) (Rotary switch)
1 unit (factory setting)	All OFF  ON OFF	 Set to 1
11 units	1 ON  ON OFF	 Set to 1
21 units	2 ON  ON OFF	 Set to 1
31 units	3 ON  ON OFF	 Set to 1
40 units	1 & 3 ON  ON OFF	 Set to 0
58 units	2 & 3 ON  ON OFF	 Set to 8
64 units	All ON  ON OFF	 Set to 4

● Examples of refrigerant circuit (R.C.) address settings (required when link wiring is used) (SW2, SW1)

System address No.	System address (SW2) (2P DIP switch) 10 20	System address (SW1) (Rotary switch)
System 1 (factory setting)	Both OFF  ON OFF	 Set to 1
System 11	1 ON  ON OFF	 Set to 1
System 21	2 ON  ON OFF	 Set to 1
System 30	1 & 2 ON  ON OFF	 Set to 0

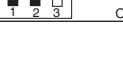

● Examples of the No. of outdoor units settings (SW6)

No. of outdoor units	Outdoor unit setting (SW6) (3P DIP switch)
1 unit (factory setting)	1 ON  ON OFF
2 units	2 ON  ON OFF
3 units	1 & 2 ON  ON OFF
4 units	3 ON  ON OFF

● Address setting of main outdoor unit (SW5)

Unit No. setting	Address setting of outdoor unit (SW5) (3P DIP switch)
Unit No. 1 (main unit) (factory setting)	 ON OFF

● Address setting of sub outdoor unit

Unit No. setting	Address setting of outdoor unit (SW5) (3P DIP switch)
Unit No. 2 (sub unit)	2 ON  ON OFF
Unit No. 3 (sub unit)	1 & 2 ON  ON OFF
Unit No. 4 (sub unit)	3 ON  ON OFF

The sub unit control PCB contains the same switches as the main unit control PCB for No. of indoor units, No. of outdoor units, and system address. However it is not necessary to set these switches.

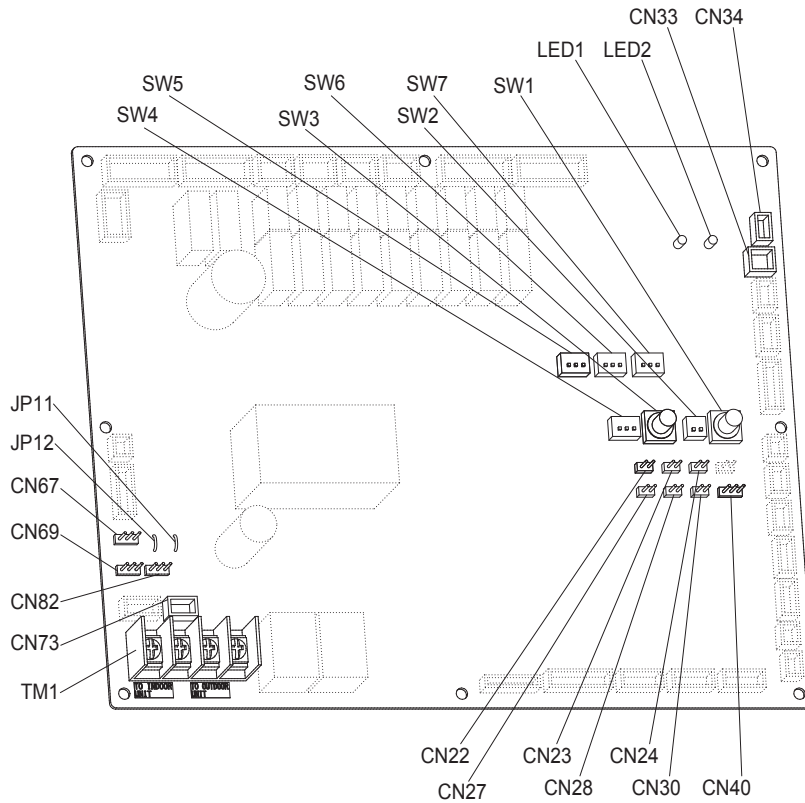

● Name And Function Of Each Switch On Outdoor Unit Control P.C. Board

Function Switch	Remarks
MODE pin (3P, BLK) (CN40)	Changes to cooling/heating mode. (outdoor main unit is only usable.) When in normal operation: When short circuited the COOL side, indoor unit operation in the same refrigerant system changes to all cooling mode. When short circuited the HEAT side, indoor unit operation in the same refrigerant system changes to all heating mode. When in auto address setting: Changes to heating mode with open-circuit.
A.ADD pin (2P, WHT) (CN30)	Short circuited for over 1 second long → Auto address setting starts with open-circuit. If short circuit lasts for over 1 second long during auto address setting, the setting is interrupted.
CHK pin (2P, WHT) (CN23)	When short circuited, test run begins. (If the remote controller is connected in test run mode, it is automatically cancelled after 1 hour.) Also, if short-circuit is cancelled, test run mode is cancelled.
RC plug (3P, BLU) (CN73)	Connects to outdoor unit maintenance remote controller and content of alarm message will be checked.
RUN pin (2P, WHT) (CN27)	When short circuited and pulse signal is given, all indoor units operate in the same refrigerant system.
STOP pin (2P, WHT) (CN28)	When short circuited and pulse signal is given, all indoor units stop in the same refrigerant system. (When short circuited, operation cannot be performed by the indoor unit's remote controller.)
AP pin (2P, WHT) (CN24)	Can be used when vacuuming the outdoor unit.
SNOW plug (3P, RED) (CN34)	Can be used when installing a snowfall sensor device.
SILENT plug (2P, WHT) (CN33)	Can be used when setting the outdoor unit fan in sound absorbing mode.
OC EMG terminal (3P, BLK) (CN69)	If "TO INDOOR UNIT" accidentally connected to high voltage, use the terminal base TM1. Method: 1. Replace the pins 1 and 2 of CN69 with the pins 2 and 3. 2. Disconnect JP11.
RC1 EMG terminal (3P, BLK) (CN82)	If "TO OUTDOOR UNIT" accidentally connected to high voltage, use the terminal base TM1. Method: 1. Replace the pins 1 and 2 of CN82 with the pins 2 and 3. 2. Disconnect JP12.

For details, refer to the Test Run Service Manual.

7-4. Auto Address Setting

Example: Basic Wiring Diagram (1)

- Case of no link wiring

(Inter-unit control wiring is not connected to a multiple system.)

Indoor unit address setting is possible without starting the compressor.

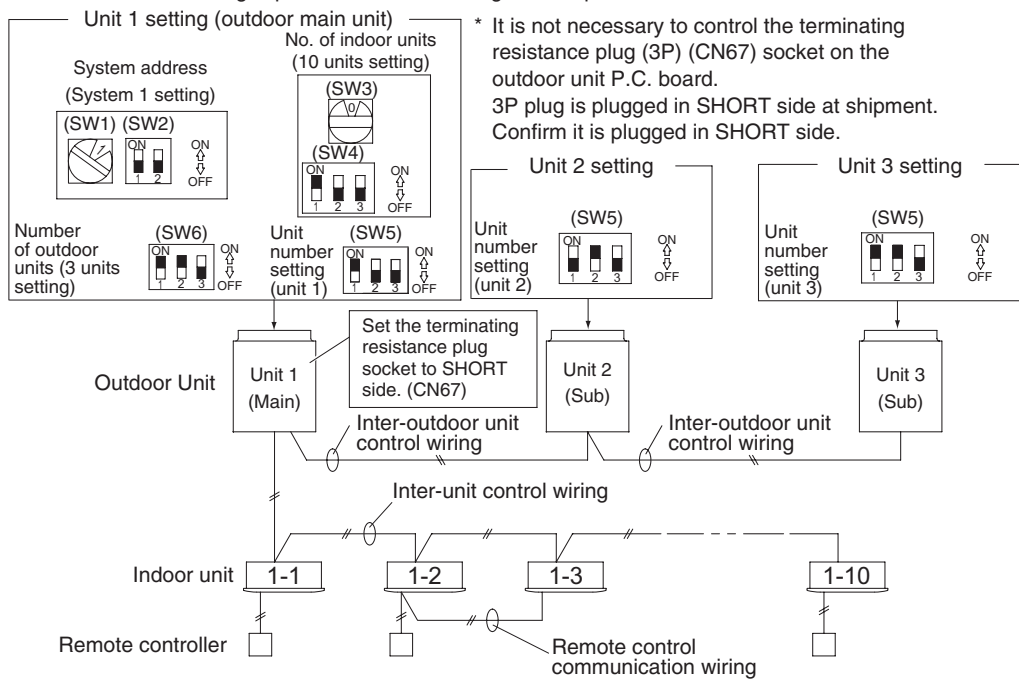

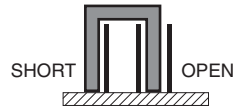

3P terminating resistance plug (SHORT side)



Case 1

Auto Address Control from Outdoor Unit

1. Regarding the number of outdoor units, set the Dip switch (SW6) for setting the number of outdoor units on Unit 1 control P.C.B to 3 units  and the Unit Number Setting Dip switch (SW5) to unit number 1. 

This unit becomes the outdoor main unit.

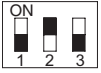
2. Set the Unit Number Setting switch (SW5) on unit 2 control P.C. board to unit number 2. 

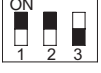
Set the Unit Number Setting switch (SW5) on unit 3 control P.C. board to unit number 3. 

3. Check the refrigerant system's Address Setting Rotary switch (SW1) on outdoor main unit control P.C. board to "1" and the Dip switch (SW2) to "0" (at shipment). 

4. Regarding the setting of the number of indoor units connected to the outdoor unit, set the Dip switch (SW4) for setting the number of indoor units on outdoor main unit control P.C. board connected to the outdoor unit to "1". 

If the Rotary switch (SW3) set to "0", 10 units can be prepared for operation.

5. Turn on power to indoor and outdoor units.
6. Short circuit the A.ADD pin (CN30) on outdoor main unit control P.C. board for over 1 second long and open circuit. Communication for auto address setting begins.

* To cancel, short circuit the A.ADD pin (CN30) again for over 1 second long and then open circuit. The LED that indicates auto address setting goes out and the process is stopped. Be sure to perform auto address setting again.

Auto address setting is completed when LEDs 1 and 2 on outdoor main unit control P.C. board go out.



7. Remote control operation is now available.

* When auto address setting is controlled by the remote controller, perform auto address setting by the remote controller after step 5 described above.

Example: Basic Wiring Diagram (2)

• Case of link wiring

* See the section "ATTENTION!"

No. 1 refrigerant system

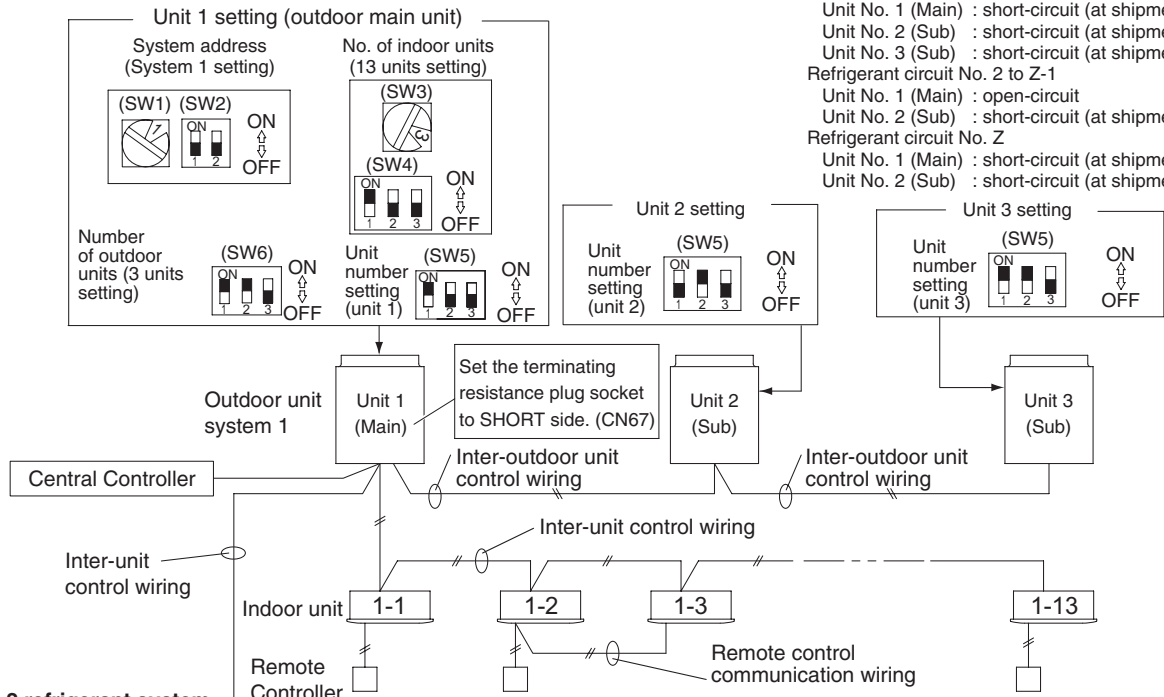

Setting of terminal plug (CN67)
 Refrigerant circuit No. 1
 Unit No. 1 (Main) : short-circuit (at shipment)
 Unit No. 2 (Sub) : short-circuit (at shipment)
 Unit No. 3 (Sub) : short-circuit (at shipment)
 Refrigerant circuit No. 2 to Z-1
 Unit No. 1 (Main) : open-circuit
 Unit No. 2 (Sub) : short-circuit (at shipment)
 Refrigerant circuit No. Z
 Unit No. 1 (Main) : short-circuit (at shipment)
 Unit No. 2 (Sub) : short-circuit (at shipment)

No. 2 refrigerant system

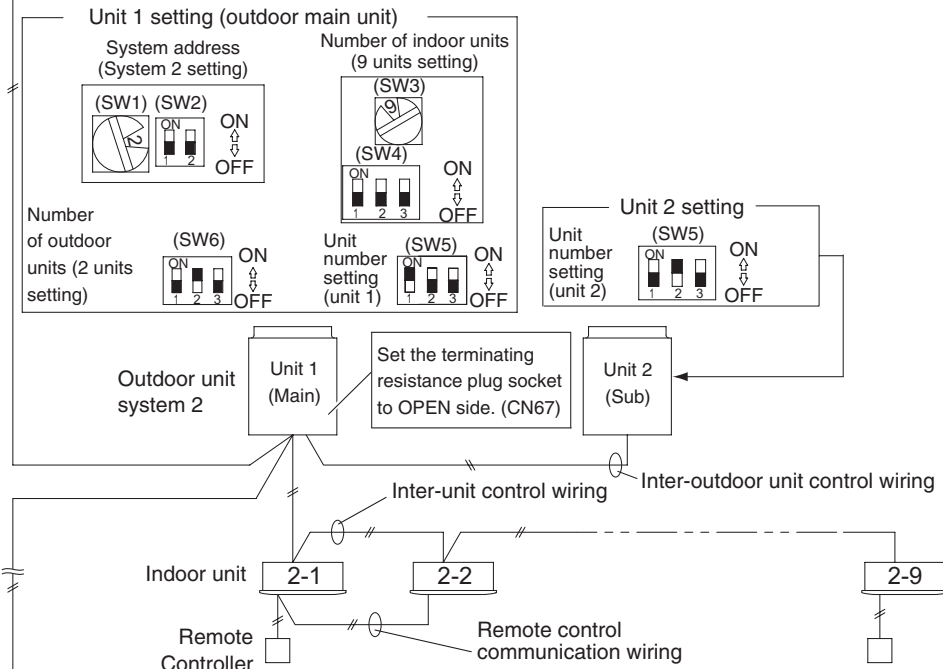

No. Z refrigerant system

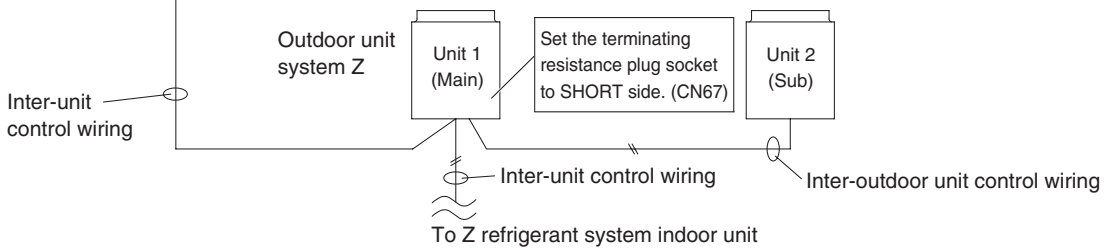

● **Final check before operation**

Final check must be done under the conditions of inter-outdoor unit control wiring connected to the centralized control system and the resistor between conductors must be measured by a Megger. Check if it is showing between 30Ω and 120Ω.

If the resistance value is out of range, check adjustment of the termination resistor again. Even if it is out of range, the problem is caused by wiring.

- Is the wiring connection properly completed?
- Are there any scratches or deterioration on the coverage?
- Measure between conductors and also between wiring and ground by 500V Megger insulation resistance tester.

Make sure the Megger is showing more than 100MΩ.

When measuring, remove both ends of the wiring from the terminal board.

If not removed, it will be damaged.

If it is less than 100MΩ, a new wiring connection should be made.

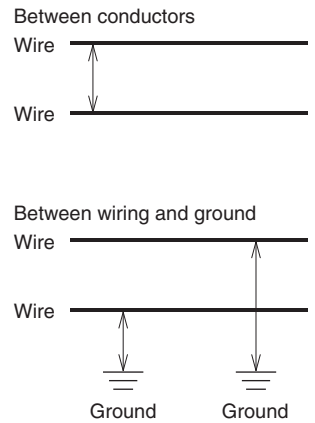

● **Make settings according to each case as described below.**

- In case of possibility of turning ON power to indoor/outdoor units for each refrigerant system → **Case 2**
- In case of impossibility of turning ON power to indoor/outdoor units for each refrigerant system
 - Auto address setting in heating mode → **Case 3.a**
 - Auto address setting in cooling mode → **Case 3.b**

Case 2 Possibility of turning ON power to indoor/outdoor units for each refrigerant system



Indoor unit address setting can be made without starting the compressor.

How to Control Auto Address Setting from Outdoor Unit

- Set the unit number setting switch (SW5) on unit 1 (outdoor main unit) control P.C. board to: 

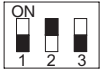
Unit 1: This unit becomes the outdoor main unit.

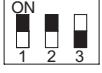
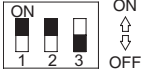
Set the unit number setting switch (SW5) on unit 2 control P.C. board to: 

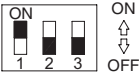
Set the unit number setting switch (SW5) on unit 3 control P.C. board to: 
- Regarding the number of outdoor units, set the Dip switch (SW6) for setting the number of outdoor units on outdoor main unit control P.C. board to 3 units. 
- Check that the refrigerant system address Rotary switch (SW1) on outdoor main unit control P.C. board in 1 refrigerant system is set to "1" and the Dip switch (SW2) is set to "0" (at shipment). 
- Regarding the number of indoor units connected to the outdoor unit, set the Dip switch (SW4) for setting the number on indoor units on outdoor main unit control P.C. board to "1"  and set the Rotary switch (SW3) to "3".

Total of 13 units installation are made.
- Turn ON power to all indoor and outdoor units in one refrigerant system.
- Short circuit the A.ADD pin (CN30) of outdoor main unit for over 1 second long and then open circuit. Communication for auto address setting begins.
 - * To cancel, again short circuit the A.ADD pin (CN30) for over 1 second long and then open circuit. LEDs 1 and 2 that indicate auto address setting is in progress go out and that process is stopped.
 - Be sure to perform auto address setting again.**

Auto address setting is completed when the compressor stops and LEDs 1 and 2 on outdoor main unit control P.C. board go out.
- Turn ON power to indoor and outdoor units only for another refrigerant system and repeat steps 1 to 5 described above. Complete auto address setting for each refrigerant system.
- Remote control operation is now available.
 - * When performing auto address setting by the remote controller, perform auto address setting by the remote controller after step 5.

Case 3.a Auto Address Setting in Heating Mode

- In case of impossibility of turning ON power to indoor/outdoor units in each refrigerant system:
Indoor unit auto address setting cannot be made unless the compressor is started.

How to Control Auto Address from Outdoor Unit

1. Make all settings following the same procedure described under steps 1 to 4 in **Case 2**.
5. Turn ON power to all indoor and outdoor units in all refrigerant systems.



6. If you wish to make auto address setting in **heating mode**, short circuit the A.ADD pin (CN30) on outdoor main unit control P.C. board for the desired auto address setting in a refrigerant system for over 1 second long and then open circuit.
Be sure to make settings in each refrigerant system. It is impossible to perform auto address setting in a multiple refrigerant system simultaneously.



Communication for auto address setting begins and the compressor is started and auto address setting in heating mode begins. All indoor units can also be operated.



- * To cancel, again short circuit the A.ADD pin (CN30) for over 1 second long and then open circuit. LEDs 1 and 2 that indicate auto address setting is in progress go out and that process is stopped.

Be sure to perform auto address setting again.

Auto address setting is completed when the compressor stops and LEDs 1 and 2 on outdoor main unit control P.C. board go out.



7. Short circuit the A.ADD pin (CN30) on outdoor main unit in another refrigerant system for over 1 second long and then open circuit.



Repeat the same procedure and complete auto address setting.

8. Remote control operation is now available.

* When installing auto address setting by the remote controller, control auto address setting by the remote controller after step 5.

- See the section "Auto Address Setting from Remote Controller".

Case 3.b Auto Address Setting in Cooling Mode

- In case of impossibility of turning ON power to indoor/outdoor units in each refrigerant system:
The indoor unit auto address setting cannot be made unless the compressor is started.

How to Control Auto Address from Outdoor Unit

1. Make all settings following the same procedure described under steps 1 to 4 of [Case 2](#).
5. Turn ON power to all indoor and outdoor units in all refrigerant systems.
6. If you wish to make auto address setting in [cooling mode](#), while short circuiting COOL side of the MODE pin (CN40) on outdoor main unit control P.C. board for the desired auto address setting, short circuit the A.ADD pin (CN30) for over 1 second long and then open circuit.
Be sure to install address settings in each refrigerant system. It is impossible to perform auto address setting in a multiple refrigerant system simultaneously.



Communication for auto address setting begins and the compressor starts and auto address setting in cooling mode begins. All indoor units can also be operated.



- * To cancel, again short circuit the A.ADD pin (CN30) for over 1 second long and then open circuit. LEDs 1 and 2 that indicate auto address setting is in progress go out and that process is stopped.

Be sure to perform auto address setting again.

Auto address setting is completed when the compressor stops and LEDs 1 and 2 on outdoor main unit control P.C. board go out.



7. Short circuit the A.ADD pin (CN30) on outdoor main unit in another refrigerant system for over 1 second long and then open circuit.



Repeat the same procedure and complete auto address setting.



8. Remote control operation is now available.

* **It is impossible to perform auto address setting in cooling mode by the remote controller.**

Auto Address Setting from the High-spec Wired Remote Controller (CZ-RTC5B)

- Keep pressing the , and buttons simultaneously for 4 or more seconds.
The "Maintenance func" screen appears on the LCD display.
- Press the or button to see each menu.
If you wish to see the next screen instantly, press the or button.
Select "9. Auto address" on the LCD display and press the button.

Maintenance func	20:30 (THU)
9. Auto address	
10. Set elec. consumption	
11. Set touch key	
12. Check touch key	
◆ Sel. ◀▶ Page [↵] Confirm	

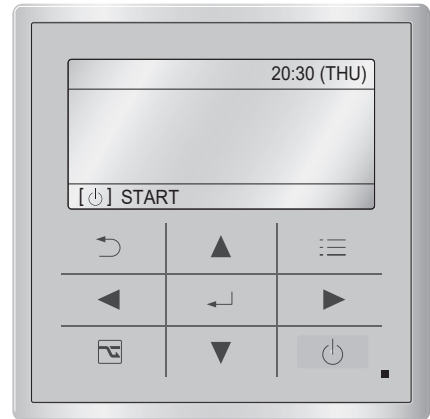

CZ-RTC5B

- The "Auto address" screen appears on the LCD display.
Change the "Code no." to "A1" by pressing the or button.

Auto address	20:30 (THU)
Code no.	O/D unit no.
A1	1
◆ Sel. ▶ Next	

- Select the "O/D unit no." by pressing the or button.
Select one of the "O/D unit no." for auto address by pressing the or button.
Approximately about 10 minutes are required.
When auto address setting is completed, the units return to normal stopped status.

Auto Address Setting* from the Remote Controller (CZ-RTC4)

* Auto address setting in Cooling mode cannot be done from the remote controller.

NOTE

- Selecting each refrigerant system individually for auto address setting
- Auto address setting for each system
: Item code "A1"

- Press the remote controller timer time button and button at the same time.
(Press and hold for 4 seconds or longer.)
- Next, press either the temperature setting / button. (Check that the item code is "A1".)
- Use either the button to set the system No. to perform auto address setting.
- Then press the button.
(Auto address setting for one refrigerant system begins.) (When auto address setting for one system is completed, the system returns to normal stopped status.)
<Approximately 4 – 5 minutes is required.>
(During auto address setting, "SETTING" is displayed on the remote controller.
This message disappears when auto address setting is completed.)
- Repeat the same steps to perform auto address setting for each successive system.

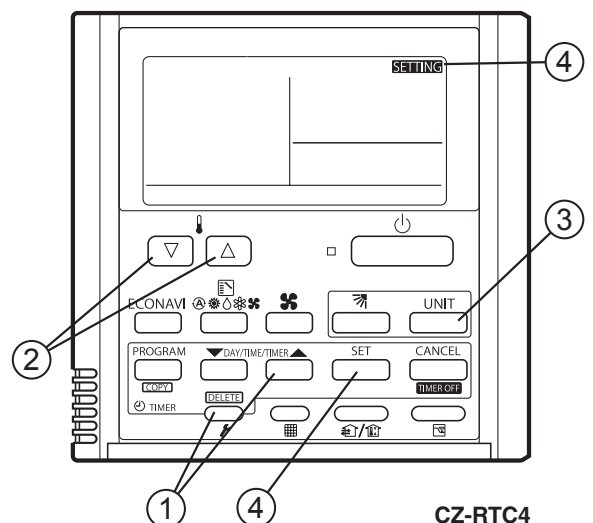

CZ-RTC4

Display During Auto Address Setting

- On the surface of outdoor unit control P.C. board

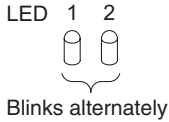

- * Do not short circuit the A.ADD pin (CN30) again during auto address setting. LEDs 1 and 2 go out and address setting is interrupted.
- * When auto address setting is normally completed, both LEDs 1 and 2 go out. In other cases, correct settings referring to the following table and perform auto address setting again.

- Contents of LEDs 1 and 2 on outdoor unit control P.C. board

- ☀ : Illuminating
- ⚡ : Blinking
- : Go out

LED 1	LED 2	Contents of display
☀	☀	After turned ON power (not during auto address setting), it is entirely impossible to communicate with the indoor unit in the system.
●	☀	After turned ON power (not during auto address setting), although the indoor units more than 1 unit in the system are recognized, there are inconsistencies between the number of indoor units and setting number of indoor units.
⚡	⚡	Under auto address setting
Alternately		
●	●	Auto address setting completed
⚡	⚡	There are inconsistencies between the number of indoor units and setting number of indoor units. (at the time of auto address setting)
Simultaneously		
⚡	⚡	See the section "7-7. Self-Diagnosis Function Table and Contents of Alarm Display".
Alternating		

- Display of remote controller

CZ-RTC5B

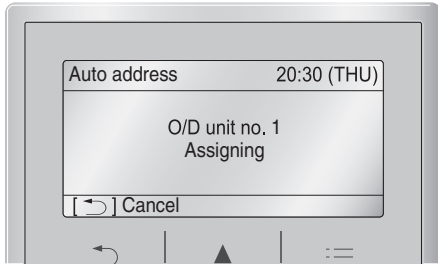

CZ-RTC4

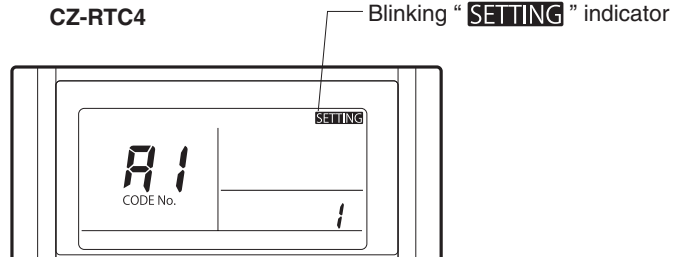

Request concerning recording the indoor/outdoor unit combination Nos.

After auto address setting has been completed, be sure to record them for future reference.

List the outdoor main unit system address and the addresses of the indoor units in that system in an easily visible location (next to the nameplate), using a permanent marking pen or similar means that cannot be abraded easily.

Example: (Outdoor) 1 - (Indoor) 1-1, 1-2, 1-3... (Outdoor) 2 - (Indoor) 2-1, 2-2, 2-3...

These numbers are necessary for later maintenance. Please be sure to indicate them.

Checking the indoor unit addresses

Use the remote controller to check the indoor unit address.

CZ-RTC5B (High-spec wired remote controller)

- Keep pressing the , and buttons simultaneously for 4 or more seconds.
The "Maintenance func" screen appears on the LCD display.

Maintenance func	20:30 (THU)
1. Outdoor unit error data	
2. Service contact	
3. RC setting mode	
4. Test run	
◆ Sel. ◀ ▶ Page [] Confirm	

- Press the or button to see each menu.
If you wish to see the next screen instantly, press the or button.
Select "7. Simple settings" on the LCD display and press the button.

Maintenance func	20:30 (THU)
5. Sensor info.	
6. Servicing check	
7. Simple settings	
8. Detailed settings	
◆ Sel. ◀ ▶ Page [] Confirm	

- The "Simple settings" screen appears on the LCD display.
Select the "Unit no." by pressing the or button for changes.

Simple settings		20:30 (THU)
Unit no.	Code no.	Set data
▲ 1-1 ▼	01	0001
◆ Sel.	▶ Next	

The indoor unit fan operates only at the selected indoor unit.

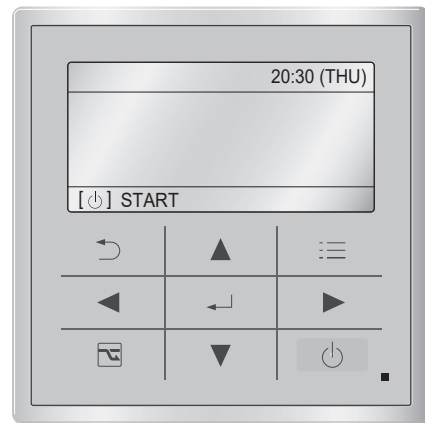

CZ-RTC5B

CZ-RTC4 (Timer remote controller)

<If 1 indoor unit is connected to 1 remote controller>

- Press and hold the button and button for 4 seconds or longer (simple settings mode).
- The address is displayed for the indoor unit that is connected to the remote controller.
(Only the address of the indoor unit that is connected to the remote controller can be checked.)
- Press the button again to return to normal remote controller mode.

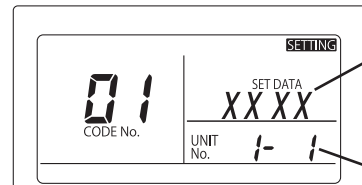

Number changes to indicate which indoor unit is currently selected.

Indoor unit address

<If multiple indoor units are connected to 1 remote controller (group control)>

- Press and hold the button and button for 4 seconds or longer (simple settings mode).
- "ALL" is displayed on the remote controller.
- Next, press the button.
- The address is displayed for 1 of the indoor units which is connected to the remote controller. Check that the fan of that indoor unit starts and that air is discharged.
- Press the button again and check the address of each indoor unit in sequence.
- Press the button again to return to normal remote controller mode.

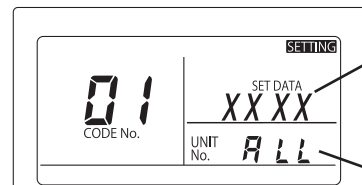

Number changes to indicate which indoor unit is currently selected.

Indoor unit address

7-5. Setting Test Run Remote Controller

CZ-RTC5B (High-spec wired remote controller)

- Keep pressing the , and buttons simultaneously for 4 or more seconds.
The "Maintenance func" screen appears on the LCD display.

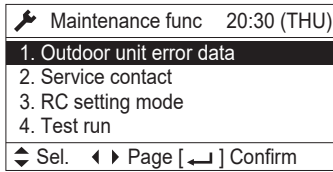

- Press the or button to see each menu.
If you wish to see the next screen instantly, press the or button.

Select "4. Test run" on the LCD display and press the button.

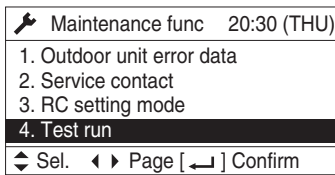

Change the display from OFF to ON by pressing the or button. Then press the button.

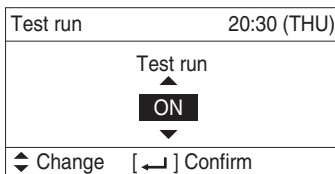

CZ-RTC4 (Timer remote controller)

- Press the remote controller button for 4 seconds or longer.
Then press the button.
- "TEST" appears on the LCD display while the test run is in progress.
- The temperature cannot be adjusted when in Test Run mode.
(This mode places a heavy load on the machines.
Therefore use it only when performing the test run.)
- The test run can be performed using the HEAT, COOL, or FAN operation modes.

NOTE

The outdoor units will not operate for approximately 3 minutes after the power is turned ON and after operation is stopped.

- If correct operation is not possible, a code is displayed on the remote controller LCD display.
(See the section "7-7. Self-Diagnostic Function Table and Contents of Alarm Display" and correct the problem.)
- After the test run is completed, press the button again.
Check that "TEST" disappears from the LCD display.
(To prevent continuous test runs, this remote controller includes a timer function that cancels the test run after 60 minutes.)

* If the test run is performed using the wired remote controller, operation is possible even if the cassette-type ceiling panel has not been installed. ("P09" display does not occur.)

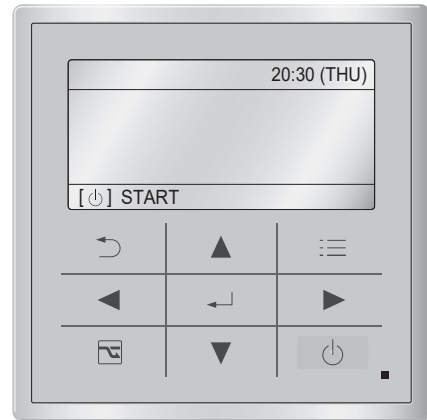

CZ-RTC5B

- Press the button. "TEST" will be displayed on the LCD display.

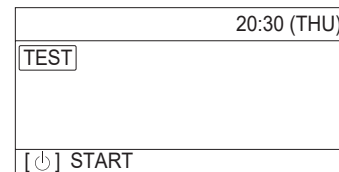

- Press the button. Test run will be started.
Test run setting mode screen appears on the LCD display.

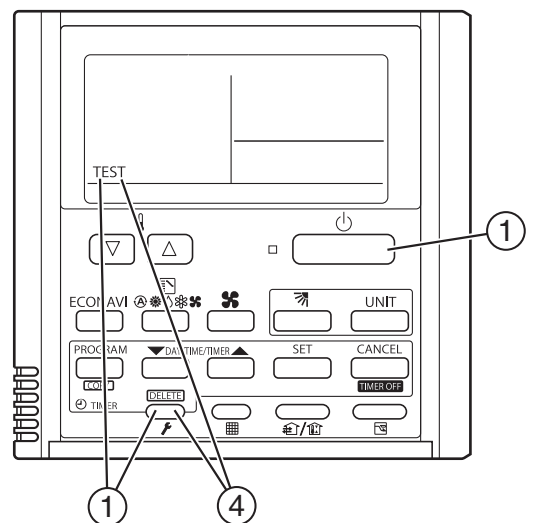
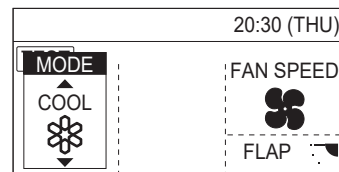

CZ-RTC4

7-6. Caution for Pump Down

Pump down means refrigerant gas in the system is returned to the outdoor unit.
 Pump down is used when the unit is to be moved, or before servicing the refrigerant circuit.
 (Refer to the Service Manual)



CAUTION

- This outdoor unit cannot collect more than the rated refrigerant amount as shown by the nameplate on the back.
- If the amount of refrigerant is more than that recommended, do not conduct pump down. In this case use another refrigerant collecting system.

7-7. Self-Diagnosis Function Table and Contents of Alarm Display

How to know LEDs 1 and 2 alarm display on outdoor unit control P.C. board

LED 1	LED 2	Contents of Alarm Display													
✱	✱	Alarm display													
Alternating		After LED1 blinks M times, LED2 blinks N times. This will be repeated.													
		M	<table border="1" style="margin-left: auto; margin-right: auto;"> <thead> <tr> <th>Number of blinks</th> <th>Type of alarm</th> </tr> </thead> <tbody> <tr> <td style="text-align: center;">2</td> <td style="text-align: center;">Alarm P</td> </tr> <tr> <td style="text-align: center;">3</td> <td style="text-align: center;">Alarm H</td> </tr> <tr> <td style="text-align: center;">4</td> <td style="text-align: center;">Alarm E</td> </tr> <tr> <td style="text-align: center;">5</td> <td style="text-align: center;">Alarm F</td> </tr> <tr> <td style="text-align: center;">6</td> <td style="text-align: center;">Alarm L</td> </tr> </tbody> </table>	Number of blinks	Type of alarm	2	Alarm P	3	Alarm H	4	Alarm E	5	Alarm F	6	Alarm L
Number of blinks	Type of alarm														
2	Alarm P														
3	Alarm H														
4	Alarm E														
5	Alarm F														
6	Alarm L														
			N = number of alarm No.												
		For example: After LED1 blinks twice, LED2 blinks 17 times. This will be repeated. The alarm shows "P17".													

(✱ : Blink) Connect the outdoor unit maintenance remote controller to the RC plug (3P, BLU) on outdoor main unit control P.C. board and make confirmation.

■ Self-Diagnosis Function Table

- Cause and countermeasure against the symptom of auto address failure

Symptom	Cause and countermeasure
<ul style="list-style-type: none"> ● When turning ON power to the outdoor main unit, LEDs 1 and 2 illuminate or blink excluding going out. Auto address setting is not available. 	See "Contents of Alarm Display" and make corrections.
<ul style="list-style-type: none"> ● When auto address setting by the remote controller begins, the alarm display appears immediately. 	
<ul style="list-style-type: none"> ● When auto address setting by the remote controller begins, no display appears. 	Are remote control wiring and inter-unit control wiring connected properly? Is indoor unit turned ON power?

- Auto address setting begins but finishes improperly.

Symptom	Cause and countermeasure
<ul style="list-style-type: none"> ● Soon after a few seconds or after a few minutes, the alarm content is displayed on the remote controller. 	See "Contents of Alarm Display" and make a correction.
<ul style="list-style-type: none"> ● After a few minutes when auto address setting begins, the compressor may occasionally start and stop several times. LEDs 1 and 2 on outdoor unit control P.C. board show the display of auto address setting with blinking alternately but LEDs 1 and 2 do not indicate the completion of auto address setting (go out). 	Are remote control wiring and inter-unit control wiring connected properly? Is indoor unit turned ON power?

- If the alarm display “E15”, “E16” and “E20” appear after auto address setting began, check the following items.

Alarm display	Alarm contents
E15	Recognized number of indoor units at the time of auto address setting are fewer than that of indoor units set by SW3 and SW4 on outdoor main unit P.C. board.
E16	Recognized number of indoor units at the time of auto address setting are more than that of indoor units set by SW3 and SW4 on outdoor main unit P.C. board.
E20	Outdoor unit could not entirely receive serial communication signal from the indoor unit within 90 seconds after auto address setting began.

Check	E15	E16	E20
Have you forgotten to turn ON power to indoor unit?	<input type="radio"/>	<input type="radio"/>	<input type="radio"/>
Are indoor and outdoor control wiring connected properly? (Check for incorrect wiring to open & short-circuit, terminal plug and remote control terminal.)	<input type="radio"/>	<input type="radio"/>	<input type="radio"/>
Is remote control wiring connected properly? (Check for open & short-circuit, wrong connection to indoor/outdoor unit control wiring terminal, inter-unit control wiring.)	<input type="radio"/>	<input type="radio"/>	<input type="radio"/>
Are the number of the connecting indoor units set by SW3 and SW4 of outdoor main unit control P.C. board connected properly?	<input type="radio"/>	<input type="radio"/>	<input type="radio"/>
Is additional appropriate amount of refrigerant charge? (Compressor ON at the time of auto address setting)	<input type="radio"/>	<input type="radio"/>	<input type="radio"/>
Is the refrigerant tubing connected properly? (Compressor ON at the time of auto address setting)	<input type="radio"/>	<input type="radio"/>	<input type="radio"/>
Are E1 and E3 sensors of indoor unit normal? (Compressor ON at the time of auto address setting)	<input type="radio"/>	<input type="radio"/>	<input type="radio"/>
Are there any wrong system address installed in indoor units caused by manual or incorrect auto address control?	<input type="radio"/>	<input type="radio"/>	<input type="radio"/>

- 1) When auto address setting from outdoor main unit control P.C. board or remote controller begins, “Under Setting” appears on the remote controller as for normal indoor units under the inter-unit control wirings and remote control wirings. LEDs 1 and 2 indicators on outdoor main unit control P.C. board blink alternately.
 - 2) If there is an error at the inter-unit control wiring of the remote controller when in the indoor unit group control, address setting may not occasionally be made although “under setting” is displayed.
 - 3) Although the alarm “E15” and “E16” are displayed, addresses will be installed in the recognized indoor units. The installed addresses can be checked by the remote controller. See the section “Checking the indoor unit address”.
- When operating the remote controller after auto address setting completed (LEDs 1 and 2 indicators on outdoor main unit control P.C. board go out), correct the symptom if the following alarms appear on the remote controller.

Remote control display	Cause
No display	Remote controller is not connected properly. (Power failure) When auto address setting was completed, the power of indoor unit was turned off.
E01	Remote controller is not connected properly. (Receiving failure from remote control) Indoor unit address was mistakenly controlled by undesired indoor unit remote controller. (Impossible to communicate with outdoor unit)
E02	Remote controller is not connected properly. (Impossible to communicate with indoor unit by remote controller)
P09	Connector of indoor unit ceiling panel is not connected properly.

If any other alarm appear on the display, refer to the Test Run Service Manual.

- Alarm display can be checked by the outdoor maintenance remote controller. When operating, refer to the Test Run Service Manual. Alarm display can also be checked by number of blinking of LEDs 1 and 2 on outdoor unit control P.C. board. (See the section “How to know LEDs 1 and 2 alarm display on outdoor unit control P.C. board” under the section “7-7. Self-Diagnosis Function Table and Contents of Alarm Display”.

Remote control display	Alarm contents
E06	Outdoor unit receiving failure from indoor unit
E12	Prohibit starting auto address setting
E15	Auto address alarm (A small number of indoor units)
E16	Auto address alarm (A large number of indoor units)

Remote control display	Alarm contents
E20	No indoor unit during auto address setting
E21	Receiving failure of main system from sub system when link wiring is used for outdoor units
E22	Receiving failure of sub system from main system when link wiring is used for outdoor units
E24	Receiving failure of relay control unit from outdoor unit(s)
E25	Failure of outdoor unit address setting (Duplicative)
E26	Inconsistencies in number of outdoor units
E29	Failure of outdoor unit to receive relay control unit
E30	Failure of transferring outdoor unit serial
E31	Wiring error between the P.C. board ([L-Pow], [HIC] wire)
F04	Compressor 1 discharge temperature sensor abnormal [DISCH1]
F05	Compressor 2 discharge temperature sensor abnormal [DISCH2]
F06	Outdoor unit heat exchanger 1 gas (inlet) temperature sensor abnormal [EXG1]
F07	Outdoor unit heat exchanger 1 liquid (outlet) temperature sensor abnormal [EXL1]
F08	Outdoor temperature sensor abnormal [TO]
F12	Compressor inlet temperature sensor abnormal [SCT]
F14	Supercooling gas temperature sensor abnormal [SCG]
F16	High pressure sensor abnormal, high-load [HPS]
F17	Low pressure sensor abnormal [LPS]
F23	Outdoor unit heat exchanger 2 gas (inlet) temperature sensor abnormal [EXG2]
F24	Outdoor unit heat exchanger 2 liquid (outlet) temperature sensor abnormal [EXL2]
F31	Outdoor unit nonvolatile memory (EEPROM) error
H01	Compressor 1 abnormal current values (Overcurrent)
H03	Compressor 1 CT sensor disconnected, short-circuit
H05	Compressor 1 discharge temperature sensor disconnected
H06	Low pressure abnormal lowering
H07	Oil loss - error
H08	Oil sensor (connection) error 1
H11	Compressor 2 abnormal current values (Overcurrent)
H13	Compressor 2 CT sensor disconnected, short-circuit
H15	Compressor 2 discharge temperature sensor disconnected
H21	Compressor 2 HIC alarm (Check for alarm P19)
H27	Oil sensor (connection) error 2
H31	Compressor 1 HIC alarm (Check for alarm P29)
L04	Outdoor unit address settings duplicated
L05	Indoor unit priority duplicated (For priority indoor)
L06	Indoor unit priority duplicated (Not for priority indoor) and outdoor unit
L10	Outdoor unit capacity settings not made
L17	Inconsistencies in outdoor unit models
L18	4-way valve coil disconnected, line disconnected
P03	Compressor 1 discharge temperature error
P04	Actuation of high pressure switch
P05	Compressor 1 open phase detection
P11	Cooling water freeze (chiller)
P14	Actuation of O ₂ sensor
P15	Compressor 2 open phase detection
P16	Compressor 1 secondary overcurrent
P17	Compressor 2 discharge temperature error
P19	Compressor 2 wiring open phase, start failure caused by DCCT failure (DC compressor start failure)
P20	High load (Forgot to open valves)
P22	Outdoor unit fan1 failure (IPM damage, overcurrent, inverter failure, DC fan lock, hole IC open phase)
P23	Inter lock not cancellation (chiller)
P24	Outdoor unit fan2 failure (IPM damage, overcurrent, inverter failure, DC fan lock, hole IC open phase)
P26	Compressor 2 secondary overcurrent
P29	Compressor 1 wiring open phase, start failure caused by DCCT failure (DC compressor start failure)

- Contents of alarm display on remote controller

For the remote controller, there are other alarm contents listed on the following table besides the alarm display on outdoor main unit control P.C. board.

Wired remote control display	Detected contents	
<E01>	Remote controller detects abnormal signal transmitted from the indoor unit.	<ul style="list-style-type: none"> ● Failure of remote controller to receive. (For group control, signal from the main unit.) ● No setting of system address, indoor unit address, indoor unit individualization / main / sub (Auto address setting not completed.)
<E02>		Remote controller not connected properly.
<<E03>>	Indoor unit failed to receive serial signal by remote controller (or central controller).	
E04	Indoor unit detects abnormal signal from outdoor main unit control P.C. board.	<ul style="list-style-type: none"> ● Receiving failure of remote controller (For group control, signal from the main unit.) ● Inconsistencies in number of connected units and setting units when outdoor unit is turned ON power. (Excepting the system address "0")
E08	Setting failure	Indoor unit address settings duplicated
<<E09>>		Main remote control settings duplicated
E18	Indoor unit communication error in group control wiring	Main indoor unit failed to receive serial signal from sub indoor unit.
<<L02>>	Setting failure	Indoor unit connected to multiple outdoor units is not for multiple type.
<L03>		Main unit settings duplicated in group control indoor units
L07		Group control wiring connected to individual control indoor unit
L08		Indoor unit address settings not made
<<L09>>		Outdoor unit capacity settings not made
<<F01>>	Indoor unit thermistor failure	Heat exchanger temperature sensor E1
<<F02>>		Water heat exchanger temperature sensor E2 (chiller)
<<F03>>		Heat exchanger temperature sensor E3
<<F10>>		Inlet temperature sensor
<<F11>>		Outlet temperature sensor
<<P09>>	Connection failure of ceiling panel or connector	
<<P01>>	Indoor unit protection	Fan protection thermostat
<<P10>>		Float switch
<<P12>>		Actuation of fan inverter protecting function
F29	Nonvolatile memory IC (EEPROM) failure on indoor unit control P.C. board	

- The parentheses of << >> used in the table of alarm display does not affect anything the operation of other indoor units.
- The parentheses of < > used in the table of alarm display implies that there are two cases : according to the content of the symptom, some affect the operation of other indoor units and others do not affect anything.

Alarm messages displayed on system controller			
Serial communication errors Mis-setting	Error in transmitting serial communication signal	Indoor or main outdoor unit is not operating correctly. Mis-wiring of control wiring between indoor unit, main outdoor unit and system controller.	C05
	Error in receiving serial communication signal	Indoor or main outdoor unit is not operating correctly. Mis-wiring of control wiring between indoor unit, main outdoor unit and system controller. CN1 is not connected properly.	C06
Activation of protective device	Protective device of sub indoor unit in group control is activated.	When using wireless remote controller or system controller, in order to check the alarm message in detail, connect wired remote controller to indoor unit temporarily.	P30

NOTE

1. Alarm messages in << >> do not affect other indoor unit operations.
2. Alarm messages in < > sometimes affect other indoor unit operations depending on the fault.

ATTENTION!

Adjustment of terminating resistance (plug) is necessary.

Communication failure will occur unless adjustment is made correctly.

- Terminating resistance (plug) is mounted on outdoor unit control P.C. board.
- When connecting central controller, interface or peripheral equipment, adjustment of terminating resistance (plug) is necessary. Although the connection is not made, confirmation is necessary for VRF systems.
- In the case of a refrigerant system, the terminating resistance (plug) for this inter-unit control wiring (S-LINK wiring) is one location (See the section “7-4. Auto Address Setting”).
For 2 or more refrigerant systems, 2 locations should be valid (“SHORT” for VRF systems at shipment). See the section “7-4. Auto Address Setting”.
In order to make 2 locations valid, let the terminating resistance (plug) of the nearest outdoor unit and the farthest outdoor unit be valid (SHORT side) from the location of central controller.
In other refrigerant systems excepting 2 locations described above, make them invalid (OPEN side).
It is prohibited making more than 3 locations of terminating resistance valid.
- Since the use of linking the sub outdoor units of VRF systems is not connected to the inter-unit control wiring, it is not necessary to make the terminating resistance invalid “OPEN side”.

Make final confirmation regarding the central controller or interface & inter-unit control wiring (S-LINK wiring) connected to the peripheral equipment.
Measure the line resistance with a tester and check whether the values are in the range of $30\Omega - 120\Omega$.
If the resistance values are out of range, check again the terminating resistance.
Nevertheless, if the values are out of range, the problem comes from wiring.

- Is the connection properly made?
- Are there any scratches or damages on the coated surface?
- Measure the line, between wires and ground with the 500V megger (insulation resistance meter) and check the values are over $100M\Omega$.
- When measuring, be sure to remove both edges of the wire from the terminal board. If not removed, it will be damaged.
- If the line resistance is within $100M\Omega$, newly carry out the wiring work.

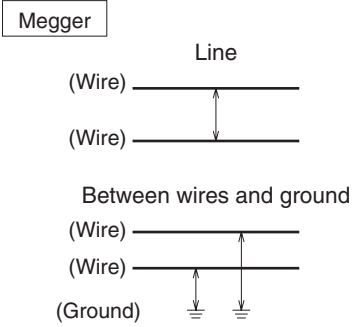

The diagram illustrates two methods for testing a line with a Megger. The first method, labeled 'Line', shows two horizontal lines representing wires, with a vertical double-headed arrow between them. The second method, labeled 'Between wires and ground', shows two horizontal lines representing wires and a ground symbol below them, with a vertical double-headed arrow between the top wire and the ground.

SUPPLEMENT

1. Combination with various type of outdoor units

Unit: mm

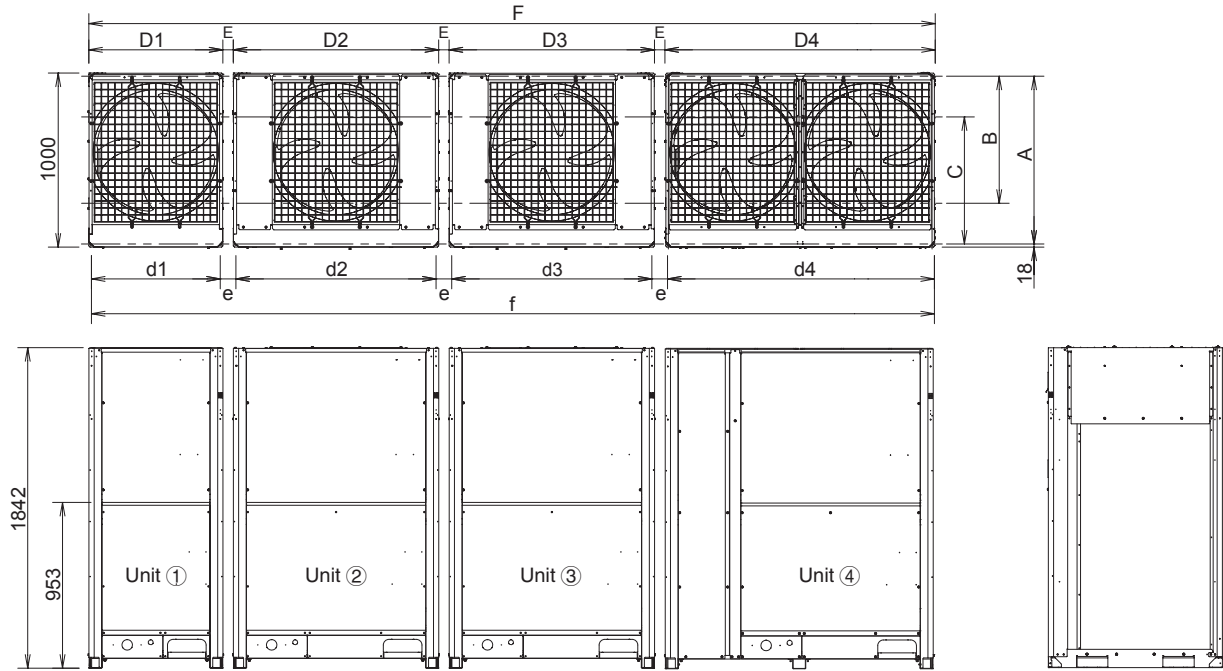

Capacity	Combination				Dimensions of single unit				Distance between units		Dimensions of combination unit		Dimensions of single unit installation hole				Distance between unit installation hole		Dimensions of combination unit installation hole	
	①	②	③	④	D1	D2	D3	D4	E(+1)	E(+2)	F(+1)	F(+2)	d1	d2	d3	d4	e(+1)	e(+2)	f(+1)	f(+2)
8HP	8	—	—	—	770	—	—	—	—	—	770	770	740	—	—	—	—	—	740	740
10HP	10	—	—	—	770	—	—	—	—	—	770	770	740	—	—	—	—	—	740	740
12HP	12	—	—	—	1180	—	—	—	—	—	1180	1180	1150	—	—	—	—	—	1150	1150
14HP	14	—	—	—	1180	—	—	—	—	—	1180	1180	1150	—	—	—	—	—	1150	1150
16HP	16	—	—	—	1180	—	—	—	—	—	1180	1180	1150	—	—	—	—	—	1150	1150
18HP	18	—	—	—	1540	—	—	—	—	—	1540	1540	1510	—	—	—	—	—	1510	1510
20HP	20	—	—	—	1540	—	—	—	—	—	1540	1540	1510	—	—	—	—	—	1510	1510
22HP	10	12	—	—	770	1180	—	—	60	180	2010	2130	740	1150	—	—	90	210	1980	2100
24HP	12	12	—	—	1180	1180	—	—	60	180	2420	2540	1150	1150	—	—	90	210	2390	2510
26HP	10	16	—	—	770	1180	—	—	60	180	2010	2130	740	1150	—	—	90	210	1980	2100
28HP	12	16	—	—	1180	1180	—	—	60	180	2420	2540	1150	1150	—	—	90	210	2390	2510
30HP	14	16	—	—	1180	1180	—	—	60	180	2420	2540	1150	1150	—	—	90	210	2390	2510
32HP	16	16	—	—	1180	1180	—	—	60	180	2420	2540	1150	1150	—	—	90	210	2390	2510
34HP	14	20	—	—	1180	1540	—	—	60	180	2780	2900	1150	1510	—	—	90	210	2750	2870
36HP	16	20	—	—	1180	1540	—	—	60	180	2780	2900	1150	1510	—	—	90	210	2750	2870
38HP	18	20	—	—	1540	1540	—	—	60	180	3140	3260	1510	1510	—	—	90	210	3110	3230
40HP	20	20	—	—	1540	1540	—	—	60	180	3140	3260	1510	1510	—	—	90	210	3110	3230
42HP	10	16	16	—	770	1180	1180	—	60	180	3250	3490	740	1150	1150	—	90	210	3220	3460
44HP	12	16	16	—	1180	1180	1180	—	60	180	3660	3900	1150	1150	1150	—	90	210	3630	3870
46HP	14	16	16	—	1180	1180	1180	—	60	180	3660	3900	1150	1150	1150	—	90	210	3630	3870
48HP	16	16	16	—	1180	1180	1180	—	60	180	3660	3900	1150	1150	1150	—	90	210	3630	3870
50HP	14	16	20	—	1180	1180	1540	—	60	180	4020	4260	1150	1150	1510	—	90	210	3990	4230
52HP	16	16	20	—	1180	1180	1540	—	60	180	4020	4260	1150	1150	1510	—	90	210	3990	4230
54HP	14	20	20	—	1180	1540	1540	—	60	180	4380	4620	1150	1510	1510	—	90	210	4350	4590
56HP	16	20	20	—	1180	1540	1540	—	60	180	4380	4620	1150	1510	1510	—	90	210	4350	4590
58HP	18	20	20	—	1540	1540	1540	—	60	180	4740	4980	1510	1510	1510	—	90	210	4710	4950
60HP	20	20	20	—	1540	1540	1540	—	60	180	4740	4980	1510	1510	1510	—	90	210	4710	4950
62HP	14	16	16	16	1180	1180	1180	1180	60	180	4900	5260	1150	1150	1150	1150	90	210	4870	5230
64HP	16	16	16	16	1180	1180	1180	1180	60	180	4900	5260	1150	1150	1150	1150	90	210	4870	5230
66HP	10	16	20	20	770	1180	1540	1540	60	180	5210	5570	740	1150	1510	1510	90	210	5180	5540
68HP	12	16	20	20	1180	1180	1540	1540	60	180	5620	5980	1150	1150	1510	1510	90	210	5590	5950
70HP	10	20	20	20	770	1540	1540	1540	60	180	5570	5930	740	1510	1510	1510	90	210	5540	5900
72HP	16	16	20	20	1180	1180	1540	1540	60	180	5620	5980	1150	1150	1510	1510	90	210	5590	5950
74HP	16	18	20	20	1180	1540	1540	1540	60	180	5980	6340	1150	1510	1510	1510	90	210	5950	6310
76HP	16	20	20	20	1180	1540	1540	1540	60	180	5980	6340	1150	1510	1510	1510	90	210	5950	6310
78HP	18	20	20	20	1540	1540	1540	1540	60	180	6340	6700	1510	1510	1510	1510	90	210	6310	6670
80HP	20	20	20	20	1540	1540	1540	1540	60	180	6340	6700	1510	1510	1510	1510	90	210	6310	6670

According to the installation site, you may choose the setting position in the depth direction of the anchor bolt from A, B or C.

A: 964: (Installation hole pitch) : For removing tube forward. Use the data with the asterisk (*) in combination of each unit dimension.

B: 730: (Installation hole pitch) : For removing tube downward. Use the data with the asterisk (*) in combination of each unit dimension.

C: 730: (Installation hole pitch) : Use the data with the asterisk (*) in combination of each unit dimension.

2. Dimensions of Wind Ducting

Reference diagram for air-discharge chamber (field supply)

Can be installed so that the air direction is to the front or rear direction.

According to the installation site, you may choose the setting position in the depth direction of the anchor bolt from "A", "B" or "C".

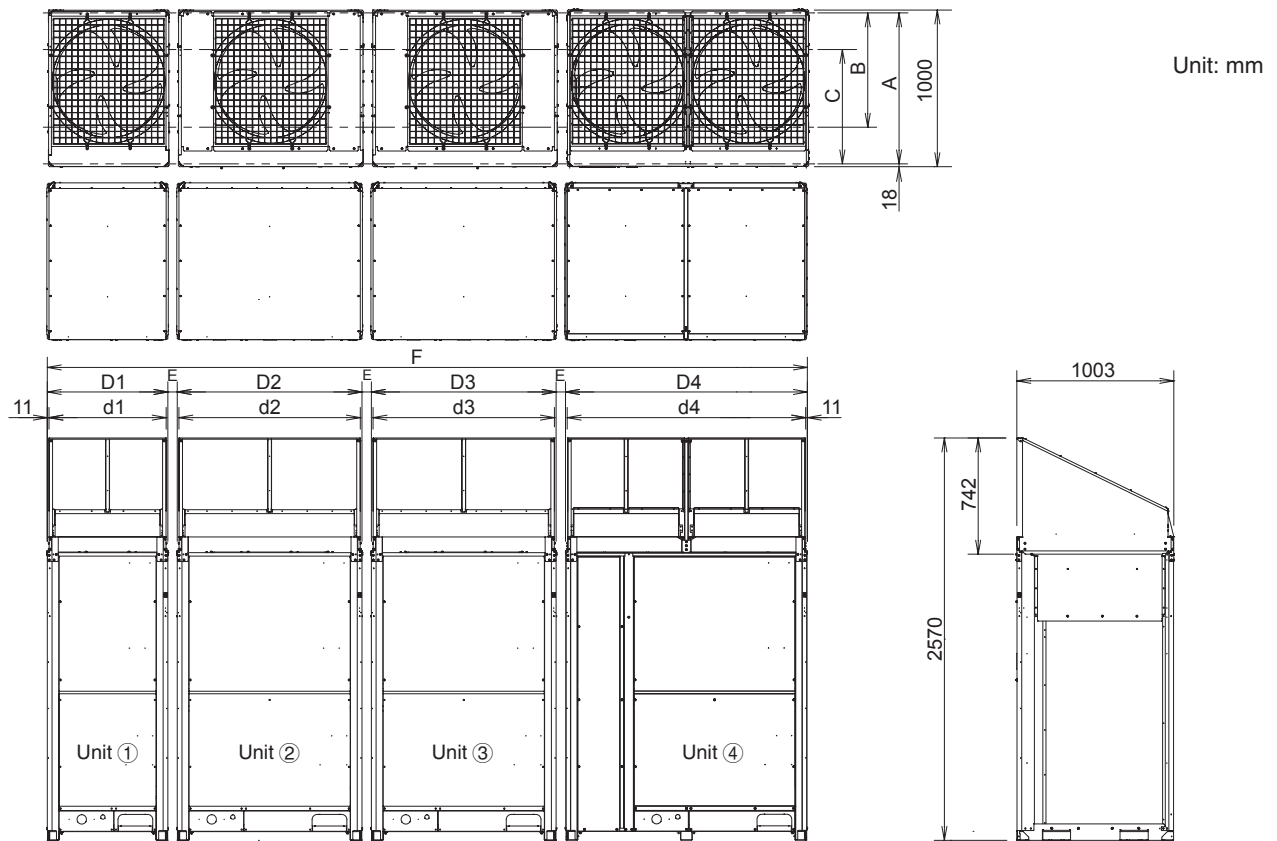

Unit: mm

Capacity	Combination				Separate dimensions of air-discharge chamber								Distance between units		Dimensions of air-discharge chamber	
	①	②	③	④	D1	D2	D3	D4	d1	d2	d3	d4	E(+1)	E(+2)	F(+1)	F(+2)
8HP	8	—	—	—	770	—	—	—	748	—	—	—	—	—	770	770
10HP	10	—	—	—	770	—	—	—	748	—	—	—	—	—	770	770
12HP	12	—	—	—	1180	—	—	—	1158	—	—	—	—	—	1180	1180
14HP	14	—	—	—	1180	—	—	—	1158	—	—	—	—	—	1180	1180
16HP	16	—	—	—	1180	—	—	—	1158	—	—	—	—	—	1180	1180
18HP	18	—	—	—	1540	—	—	—	1518	—	—	—	—	—	1540	1540
20HP	20	—	—	—	1540	—	—	—	1518	—	—	—	—	—	1540	1540
22HP	10	12	—	—	770	1180	—	—	748	1158	—	—	60	180	2010	2130
24HP	12	12	—	—	1180	1180	—	—	1158	1158	—	—	60	180	2420	2540
26HP	10	16	—	—	770	1180	—	—	748	1158	—	—	60	180	2010	2130
28HP	12	16	—	—	1180	1180	—	—	1158	1158	—	—	60	180	2420	2540
30HP	14	16	—	—	1180	1180	—	—	1158	1158	—	—	60	180	2420	2540
32HP	16	16	—	—	1180	1180	—	—	1158	1158	—	—	60	180	2420	2540
34HP	14	20	—	—	1180	1540	—	—	1158	1518	—	—	60	180	2780	2900
36HP	16	20	—	—	1180	1540	—	—	1158	1518	—	—	60	180	2780	2900
38HP	18	20	—	—	1540	1540	—	—	1518	1518	—	—	60	180	3140	3260
40HP	20	20	—	—	1540	1540	—	—	1518	1518	—	—	60	180	3140	3260
42HP	10	16	16	—	770	1180	1180	—	748	1158	1158	—	60	180	3250	3490
44HP	12	16	16	—	1180	1180	1180	—	1158	1158	1158	—	60	180	3660	3900
46HP	14	16	16	—	1180	1180	1180	—	1158	1158	1158	—	60	180	3660	3900
48HP	16	16	16	—	1180	1180	1180	—	1158	1158	1158	—	60	180	3660	3900
50HP	14	16	20	—	1180	1180	1540	—	1158	1158	1518	—	60	180	4020	4260
52HP	16	16	20	—	1180	1180	1540	—	1158	1158	1518	—	60	180	4020	4260
54HP	14	20	20	—	1180	1540	1540	—	1158	1518	1518	—	60	180	4380	4620
56HP	16	20	20	—	1180	1540	1540	—	1158	1518	1518	—	60	180	4380	4620
58HP	18	20	20	—	1540	1540	1540	—	1518	1518	1518	—	60	180	4740	4980
60HP	20	20	20	—	1540	1540	1540	—	1518	1518	1518	—	60	180	4740	4980
62HP	14	16	16	16	1180	1180	1180	1180	1158	1158	1158	1158	60	180	4900	5260
64HP	16	16	16	16	1180	1180	1180	1180	1158	1158	1158	1158	60	180	4900	5260
66HP	10	16	20	20	770	1180	1540	1540	748	1158	1518	1518	60	180	5210	5570
68HP	12	16	20	20	1180	1180	1540	1540	1158	1158	1518	1518	60	180	5620	5980
70HP	10	20	20	20	770	1540	1540	1540	748	1518	1518	1518	60	180	5570	5930
72HP	16	16	20	20	1180	1180	1540	1540	1158	1158	1518	1518	60	180	5620	5980
74HP	16	18	20	20	1180	1540	1540	1540	1158	1518	1518	1518	60	180	5980	6340
76HP	16	20	20	20	1180	1540	1540	1540	1158	1518	1518	1518	60	180	5980	6340
78HP	18	20	20	20	1540	1540	1540	1540	1518	1518	1518	1518	60	180	6340	6700
80HP	20	20	20	20	1540	1540	1540	1540	1518	1518	1518	1518	60	180	6340	6700

The air-discharge chamber will be obtained at a local field. According to the installation site, you may choose the setting position in the depth direction of the anchor bolt from A, B or C.

A: 964 (Installation hole pitch) : For removing tube forward. Use the data with the asterisk (*1) in combination of each unit dimension.

B: 730 (Installation hole pitch) : For removing tube downward. Use the data with the asterisk (*2) in combination of each unit dimension.

C: 730 (Installation hole pitch) : Use the data with the asterisk (*2) in combination of each unit dimension.

3. Dimensions of Snow Ducting

Reference diagram for snow-proof vents (field supply)

According to the installation site, you may choose the setting position in the depth direction of the anchor bolt from “A”, “B” or “C”.

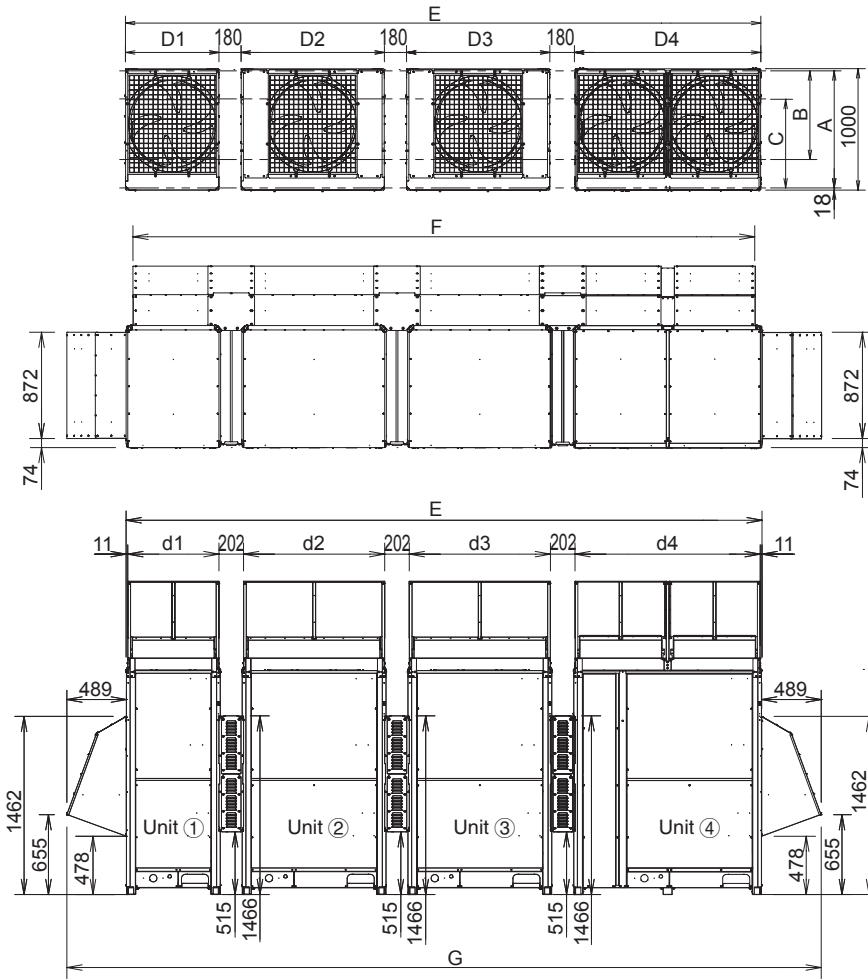

Unit: mm

The snow-proof vents will be obtained at a local field.

According to the installation site, you may choose the setting position in the depth direction of the anchor bolt from A, B or C.

- A: 964 (Installation hole pitch) :
For removing tube forward.
- B: 730 (Installation hole pitch) :
For removing tube downward.
- C: 730 (Installation hole pitch)

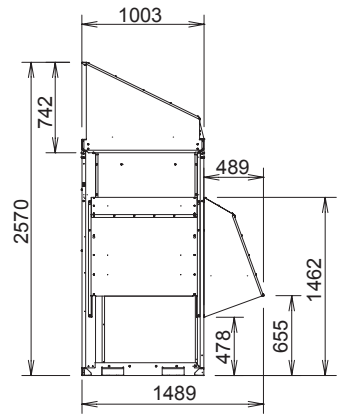

Capacity	Combination				Separate dimensions of snow-proof vents								Units dimensions		Dimensions of snow-proof vents	
	①	②	③	④	D1	D2	D3	D4	d1	d2	d3	d4	E	F	G	
8HP	8	—	—	—	770	—	—	—	748	—	—	—	770	663	1748	
10HP	10	—	—	—	770	—	—	—	748	—	—	—	770	663	1748	
12HP	12	—	—	—	1180	—	—	—	1158	—	—	—	1180	1073	2158	
14HP	14	—	—	—	1180	—	—	—	1158	—	—	—	1180	1073	2158	
16HP	16	—	—	—	1180	—	—	—	1158	—	—	—	1180	1073	2158	
18HP	18	—	—	—	1540	—	—	—	1518	—	—	—	1540	1433	2518	
20HP	20	—	—	—	1540	—	—	—	1518	—	—	—	1540	1433	2518	
22HP	10	12	—	—	770	1180	—	—	748	1158	—	—	2130	2023	3108	
24HP	12	12	—	—	1180	1180	—	—	1158	1158	—	—	2540	2433	3518	
26HP	10	16	—	—	770	1180	—	—	748	1158	—	—	2130	2023	3108	
28HP	12	16	—	—	1180	1180	—	—	1158	1158	—	—	2540	2433	3518	
30HP	14	16	—	—	1180	1180	—	—	1158	1158	—	—	2540	2433	3518	
32HP	16	16	—	—	1180	1180	—	—	1158	1158	—	—	2540	2433	3518	
34HP	14	20	—	—	1180	1540	—	—	1158	1518	—	—	2900	2793	3878	
36HP	16	20	—	—	1180	1540	—	—	1158	1518	—	—	2900	2793	3878	
38HP	18	20	—	—	1540	1540	—	—	1518	1518	—	—	3260	3153	4238	
40HP	20	20	—	—	1540	1540	—	—	1518	1518	—	—	3260	3153	4238	
42HP	10	16	16	—	770	1180	1180	—	748	1158	1158	—	3490	3383	4468	
44HP	12	16	16	—	1180	1180	1180	—	1158	1158	1158	—	3900	3793	4878	
46HP	14	16	16	—	1180	1180	1180	—	1158	1158	1158	—	3900	3793	4878	
48HP	16	16	16	—	1180	1180	1180	—	1158	1158	1158	—	3900	3793	4878	
50HP	14	16	20	—	1180	1180	1540	—	1158	1158	1518	—	4260	4153	5238	
52HP	16	16	20	—	1180	1180	1540	—	1158	1158	1518	—	4260	4153	5238	
54HP	14	20	20	—	1180	1540	1540	—	1158	1518	1518	—	4620	4513	5598	
56HP	16	20	20	—	1180	1540	1540	—	1158	1518	1518	—	4620	4513	5598	
58HP	18	20	20	—	1540	1540	1540	—	1518	1518	1518	—	4980	4873	5958	
60HP	20	20	20	—	1540	1540	1540	—	1518	1518	1518	—	4980	4873	5958	
62HP	14	16	16	16	1180	1180	1180	1180	1158	1158	1158	1158	5260	5153	6238	
64HP	16	16	16	16	1180	1180	1180	1180	1158	1158	1158	1158	5260	5153	6238	
66HP	10	16	20	20	770	1180	1540	1540	748	1158	1518	1518	5570	5463	6548	
68HP	12	16	20	20	1180	1180	1540	1540	1158	1158	1518	1518	5980	5873	6958	
70HP	10	20	20	20	770	1540	1540	1540	748	1518	1518	1518	5930	5823	6908	
72HP	16	16	20	20	1180	1180	1540	1540	1158	1158	1518	1518	5980	5873	6958	
74HP	16	18	20	20	1180	1540	1540	1540	1158	1518	1518	1518	6340	6233	7318	
76HP	16	20	20	20	1180	1540	1540	1540	1158	1518	1518	1518	6340	6233	7318	
78HP	18	20	20	20	1540	1540	1540	1540	1518	1518	1518	1518	6700	6593	7678	
80HP	20	20	20	20	1540	1540	1540	1540	1518	1518	1518	1518	6700	6593	7678	

– NOTE –

